

# KOMATSU®

## **FH70-2** **FH80-2**

*Tier 4 Final Engine*

**DIESEL FORKLIFT TRUCK**



Photos may include optional equipment.

**RATED CAPACITY**

15,400 - 18,000 lb  
7000 - 8000 kg

**LOAD CENTER**

24 in.  
600 mm

FH SERIES

# WALK-AROUND

FH70-2 / FH80-2



FH80-2

Photos may include optional equipment.

**RATED CAPACITY**

15,400 - 18,000 lb  
7000 - 8000 kg

**LOAD CENTER**

24 in.  
600 mm

## Ecology & Economy

- Komatsu's new diesel engine meets U.S. EPA Tier 4 Final standards
- Superior fuel economy
- Outstanding environment-friendliness

## Workability & Durability

- Using field proven technologies used in Komatsu's construction machinery, the FH-2 features both "Electronically - controlled Hydro-Static Transmission (HST)" and "Variable displacement pump with Closed-center Load Sensing System (CLSS)"
- Komatsu's HST provides excellent controllability with maximized efficiency
- Komatsu designed & manufactured components offer exceptional durability and reliability
- Heavy-duty sealed wet multi-disc brakes provide added braking assurance with minimal maintenance

## KOMTRAX

- KOMTRAX can communicate the machine's condition daily, which enables real-time remote fleet management and support to maximize fleet efficiencies
- Machine conditions are visible at a glance with the FH-2's large multi-function display

## Comfort & Efficiency

- Full suspension seat with ergonomic & efficient control layout reduces operator fatigue
- Spacious operator compartment increases operator comfort

# KOMTRAX®



FH70-2

# ECOLOGY & ECONOMY

## KOMATSU NEW DIESEL ENGINE TECHNOLOGIES

### Komatsu's new engine meets the U.S. EPA Tier 4 Final standard.

The Komatsu SAA4D95LE-6 engine is U.S. EPA Tier 4 Final emission certified. It provides exceptional performance while reducing fuel consumption thanks to a Heavy-duty High-Pressure Common Rail fuel injection system and an electronic control system. Based on Komatsu proprietary technologies developed over many years, this new diesel engine reduces exhaust gas particulate matter (PM) by more than 90% as compared to the Tier 4 Interim levels. Engines, electronics and hydraulic components are all developed by Komatsu in-house and are designed to work cohesively. Komatsu has achieved great advancements in technology, providing high levels of performance and efficiency in virtually all applications.

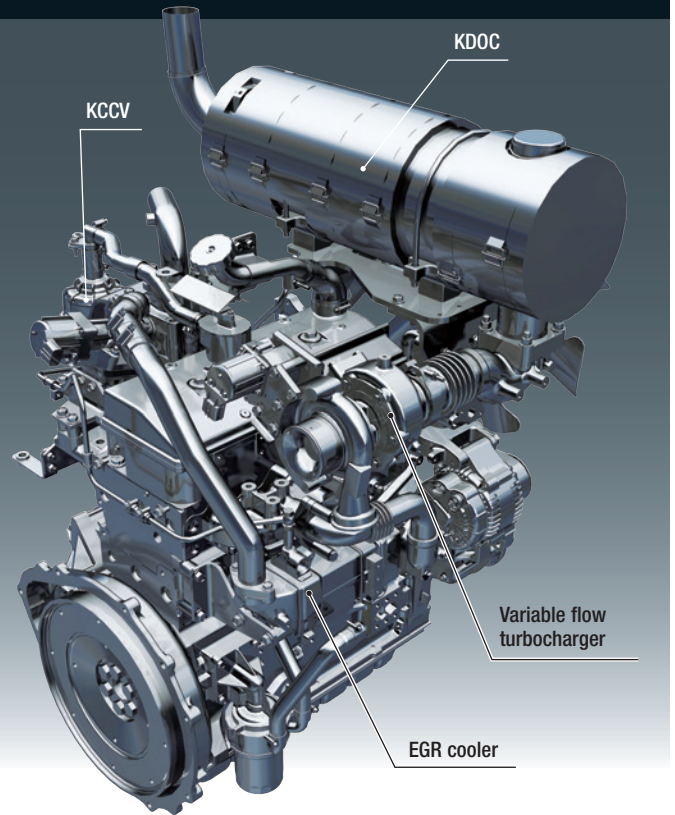

## KOMATSU'S ADVANCED ENGINE TECHNOLOGIES

### Komatsu Diesel Oxidation Catalyst (KDOC)

Komatsu has developed a simple and highly efficient diesel oxidation catalyst, which reduces PM resulting in cleaner exhaust gas. Unlike a diesel particulate filter system, need for regeneration is eliminated, thus there is no excess maintenance required and there is no downtime for regeneration. A high performance silencer that contributes to the reduction of engine noise, is also integrated.

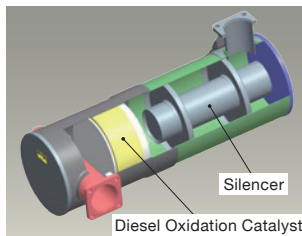

### Cooled Exhaust Gas Recirculation (EGR)

Cooled EGR system recirculates a portion of the exhaust gas for combustion and reduces NOx emissions, which results in cleaner exhaust gas.

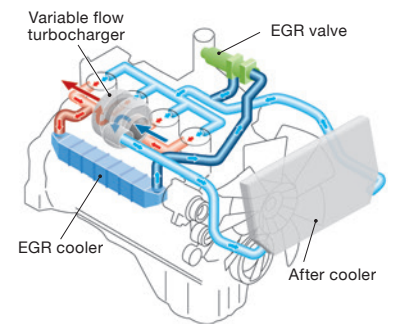

### Variable Flow Turbocharger

A newly designed variable flow turbocharger enables delivery of an optimal volume of air to the engine combustion chamber under all speed and load conditions. Exhaust turbine wheel speed is controlled by a flow control valve which controls air flow amount. The result is cleaner exhaust gas while maintaining engine power and performance.

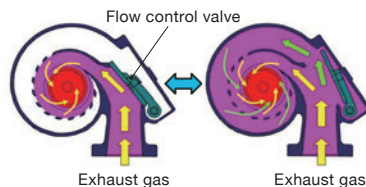

### Komatsu Closed Crankcase Ventilation (KCCV)

Crankcase emissions (Blowby gas) are passed through a KCCV filter. The filter then traps oil mist which is returned back to the crankcase for combustion. NOx emission is reduced, resulting in cleaner exhaust gas.



FH70-2/FH80-2

## Superior Fuel Economy

### Up to 30% fuel saving

The FH series incorporates the combination of the high efficiency Komatsu engine, “Electronically-controlled HST” and “Variable displacement pump with CLSS” technologies, that can provide powerful performance with at most 30% reduction of fuel consumption.

Significant fuel economy can be achieved especially in high cycle operations where fast-paced loading, unloading, and directional changes are prevalent.

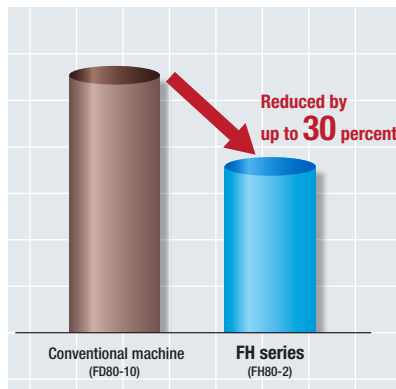

### Fuel consumption

**Up to 30% fuel saving** (FH80-2)

\* Komatsu tested data comparing the FH80-2 and FD80-10. The results may vary depending on conditions.

### Auto engine shut down function

An auto engine shut down function is equipped as standard. If the operator applies the parking brake, sets the directional lever in the neutral position and leaves the forklift truck but without stopping the engine, the engine is automatically shut down after a preset time. This feature prevents unnecessary fuel consumption caused by needless idling.

(Engine shutdown time can be set from 1 minute to 5 minutes)

## Outstanding Environment-friendliness

### Reduced CO<sub>2</sub> emission

The reduced fuel consumption enables reducing CO<sub>2</sub> emissions. In case of high load work, in annual 14.3 ton CO<sub>2</sub> emission can be reduced.

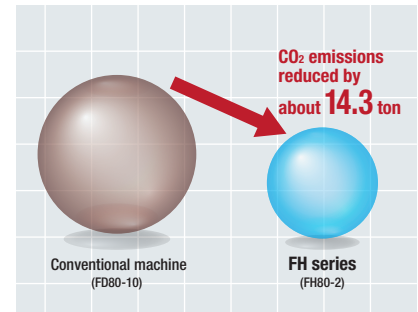

\* Komatsu tested data comparing the FH80-2 and FD80-10. Operation time is 5 hours/day, 300 days/year. The CO<sub>2</sub> emissions coefficient is calculated according to the guidelines (April 2006) shared by the Ministry of Economy, Trade and Industry and the Ministry of Land, Infrastructure, Transport and Tourism of Japan. The results may vary depending on conditions.

### Average fuel consumption / Instant fuel consumption gauge

The average fuel consumption and the instant fuel consumption gauges are integrated into the large multi-function display. This supports fuel-saving, economical driving and contributes to reducing environmental impact.

(See page 9)



# WORKABILITY & DURABILITY

**"Electronically – Controlled Hydro-Static Transmission (HST)" and "Variable Displacement Pump With Closed-Center Load Sensing System (CLSS)" Are Both Technologies That Have Been Field Proven For Many Years In Komatsu Wheel Loaders, Dozers, and Excavators.**

The hydraulic lift system uses a "Variable displacement pump with CLSS", a highly efficient hydraulic system employed in Komatsu hydraulic excavators. All the components contribute to outstanding controllability as well as fuel savings and a reduced burden on the environment.



## ■ Electronically - controlled HST

In this system, the engine rotates the hydraulic pump and the hydraulic power is transmitted to the hydraulic motor. Since this system does not have a clutch, there is no possibility of heat loss or slippage which could be caused by the inching operation. Thus the system minimizes power transmission losses.

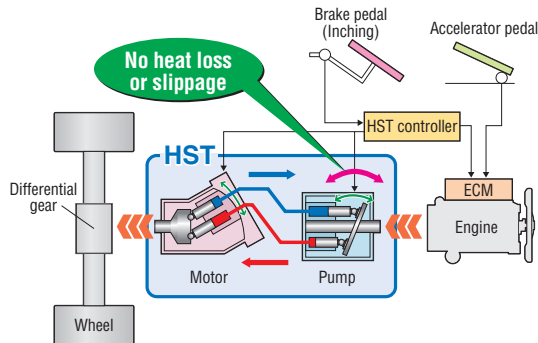

## ■ Conventional torque converter-drive forklift truck

The transmission loss is created in the torque converter and in the clutch respectively. This type of system might generate more heat and slippage of the clutch, especially if used in a high cycle application where the inching pedal is used frequently.

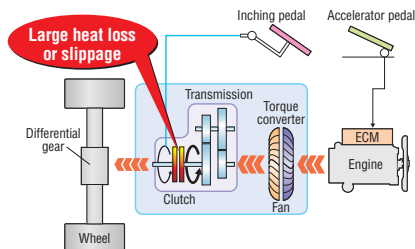

## ■ Variable displacement pump with CLSS

The pump supplies just the amount of oil needed to do specific work, and there is no loss of hydraulic oil. This system makes very efficient use of the engine power, resulting in reduced fuel consumption. With this system the operator also can lift the load with the engine running at slow speeds.

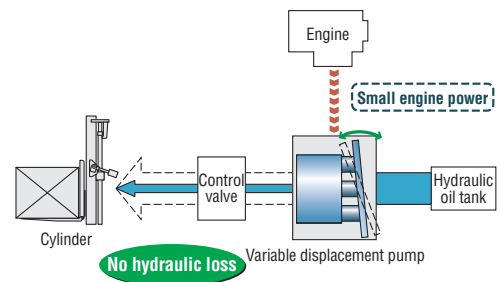

## ■ Conventional Fixed Displacement Gear Pump

Fixed displacement gear pumps deliver a specific amount of oil per rotation. Many times this delivers an excessive amount of oil and leads to added loading on the engine and added fuel consumption.

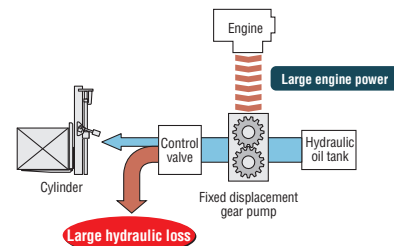

## Electronically-controlled HST Provides Exceptional Operability

### Shock-free shifting

The HST drive system is continuously a variable speed transmission and provides smooth acceleration and stepless ratio changes, thus there are less shock and worries for load shifting.



### Smooth directional changes without releasing the accelerator pedal

The engine is not mechanically connected to the drive system, but rather connected hydraulically to transmit tractive force, making it possible for the FH series forklift trucks to make directional changes smoothly without the need to release the accelerator pedal. This greatly enhances ease of operation.

\* For safer operation, slow down before directional changes.



## High-quality and Reliable Komatsu Components

All of the FH series main components, such as engine, hydraulic pumps, hydraulic motor, axles and controllers are designed, developed and manufactured by Komatsu, ensuring the quality and reliability that comes from exacting Komatsu engineering standards.

### Hydraulic Connections with O-ring Seals

Hydraulic connectors in the truck use flat face-to-face O-ring type seals, which provide a secure seal to prevent oil leakage. These connectors are field proven and very reliable and are widely used in Komatsu construction machinery.

### Controlled rollback on a ramp

The HST drive system has a self-braking feature which stops the flow of hydraulic fluid when the operator releases the accelerator pedal. This prevents uncontrolled rollback and holds the truck on a ramp while the operator releases the brake pedal for a ramp-start.



### Precise and secure slow speed travel control

Slow speed load handling can be carried out easily and smoothly by simply working the accelerator pedal, resulting in less operator fatigue.



### No creeping

The FH series does not creep like conventional torque converter machines even if the operator releases the brake pedal while the directional lever is in the F or R position. Machine movement only occurs when the operator depresses the accelerator pedal. This feature contributes to reduced risks in confined areas and when load handling.

\*For safe operation, be sure to apply the parking brake when parking the forklift.

## Heavy-duty Sealed Wet Multiple-disc Brakes

FH series forklifts are equipped with sealed wet multiple-disc brakes. Their performance is field-proven in Komatsu construction equipment. The sealed wet multiple-disc brakes provide protection from dust, dirt and debris, providing superior durability, fade and water resistance, promoting constant and stable brake performance in high cycle operations.

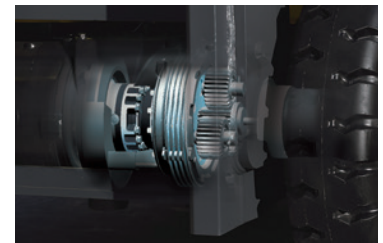

# KOMTRAX

## KOMTRAX Wireless Equipment Monitoring System

KOMTRAX, a standard feature on the FH-2, is Komatsu's remote equipment and fleet monitoring system. Leading-edge wireless technology and a secure, user-friendly, web-based application provide critical information; anytime, anywhere. KOMTRAX tells you where your machines are, what they are doing, and how they are doing it, providing total fleet management capabilities for improved fleet utilization, reduced downtime, and lower ownership and operating costs. KOMTRAX can help keep your machines operating at peak performance and provides useful information on operator habits and abilities. KOMTRAX also provides the information you need to maximize output through increased efficiencies, just-in-time maintenance, and preventative maintenance.

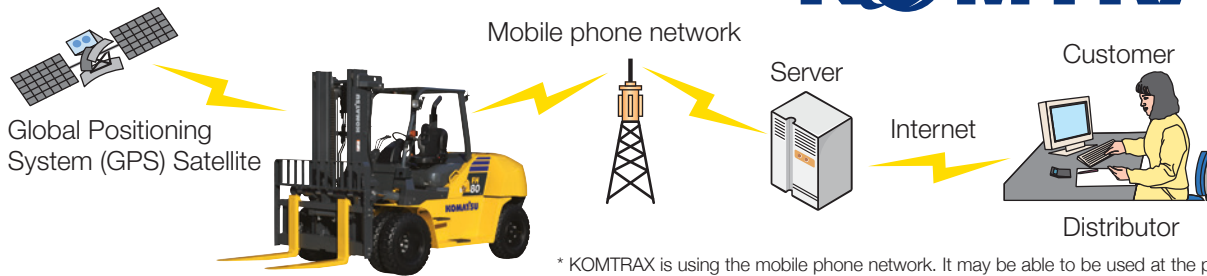

## Machine Operation Information

Getting details of machine operation on a daily basis allows owners to analyze costs and take measures to reduce those costs as needed to improve their operations bottom line.

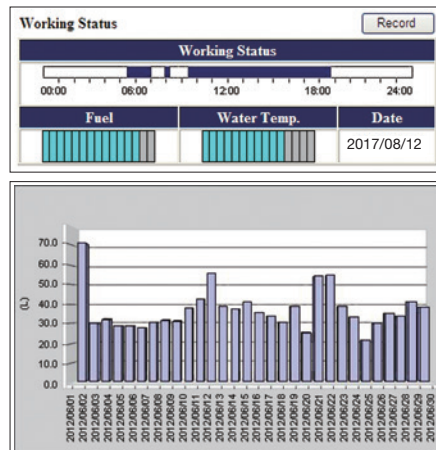

## Operation Report

Daily, monthly and annual reports provide summaries of all critical data to help with fleet utilization analysis, scheduling and overall fleet management decisions.

**Monthly Operation Report in Detail**

Table with columns: Date, Machine No., Model, Type, Serial No., Contact No., Location, Working Hours, Fuel Consumption, Water Temp., etc.

Customer Name: KOMATSU, Sales: SALES\_KOMATSU, Contact Address: [Redacted]

## Machine Location Information

KOMTRAX uses a network of global positioning satellites to tell you where your machines are at all times. This can discourage or eliminate the possibility of theft or unapproved usage as well as providing necessary information for scheduling maintenance and operations management.

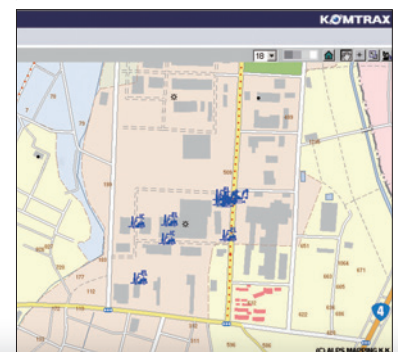

FH70-2/FH80-2



## LARGE HIGH RESOLUTION LCD MONITOR

Access machine condition at a glance with the large multi-function display

The FH-2 features a large high resolution LCD dash mounted multi-function display so the operator can easily access machine conditions with a quick glance.

Truck speed and fuel economy can be viewed and more detailed information such as operation time and fuel consumption can be displayed via function buttons.



- 1 Hour Meter (Service Meter Readings (SMR)) Integration State
- 2 Parking Brake Indicator
- 3 Load Handling Interlock Indicator
- 4 Travel Interlock Indicator
- 5 KOMTRAX Message
- 6 Engine Coolant Temperature Indicator
- 7 HST Oil Temperature Indicator
- 8 Seat Belt Caution Indicator
- 9 Parking Brake Reminder Caution Lamp
- 10 Clock / Hour Meter (SMR) / Travel Distance (Odometer) Indicator / Caution Symbol
- 11 Current Travel Speed / Over Speed caution / Travel Speed (Tortoise) Set Indicator
- 12 Directional Lever Position
- 13 Preheating Pilot Indicator
- 14 Fuel Consumption Gauge / Load Checker
- 15 Fuel Gauge
- 16 Current Consumption Level Indicator
- 17 Guidance Icon
- 18 Function Button

### Fuel Consumption

The display shows the machine's average fuel consumption as well as a gauge that shows current fuel consumption levels

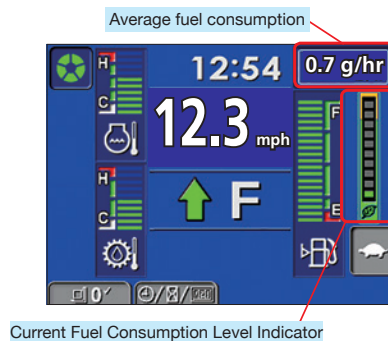

### Fuel Consumption Record

The average fuel consumption history of the machine can be checked for the last twelve hours or for other selected time periods.



### Maintenance History

The machine can record and track maintenance history, such as oil and filter changes, fuel filter changes and time remaining until the next required maintenance.



### Operation Information Display

Operation information can be checked by pressing the function buttons.

- Working Hours
- Actual Fuel Consumption
- Average Fuel Consumption
- Actual Working Hours

### Adjustable Performance Settings

The performance of the machine can be adjusted through the display panel to meet the needs of various operators and work sites



# COMFORT & EFFICIENCY

## OPERATOR FRIENDLY ACCESSORIES

### Seat Belt Caution Indicator

This warning alerts the driver when the seat belt is not fastened. Furthermore, the seat belt color is bright orange, ensuring that the seat belt is visible when in use.



### KOPS Plus

The Komatsu Operator Presence Sensing system incorporates a Lifting/Traveling interlock function. This function disables traveling and lifting when the operator is not correctly in the seat. An alarm buzzer sounds if the operator leaves the seat while traveling.

\* The traveling interlocking function only disengages traction and does not automatically apply the brakes.

### Neutral Start Function

The FH-2 series engine will only start when the operator is in the seat, the directional lever is in the neutral position and the brake pedal is kept depressed.



### Travel Speed Limiter

Travel speeds can be set in 3 stages. This function is useful to reduce speeds in tight spaces or to keep the forklift within specific in-plant speed limitations. (Set travel speed: 3, 5, 9 mph or OFF)

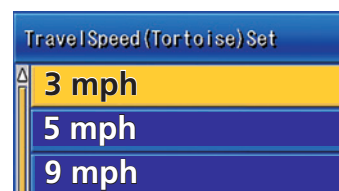

### Lift Prevention When Key Is Off

When the key switch is off, the lift function is locked and assures that the forks and mast will not operate if the control lever is moved accidentally, thus reducing risk.

### Parking Brake Warning

If the driver gets off the machine without setting the parking brake, a warning light flashes and the buzzer intermittently sounds to prevent the parking brake from being forgotten. Also, if the driver steps on the acceleration pedal with the parking brake on, the buzzer sounds to prevent driving with the parking brake on.



FH70-2 / FH80-2

### Load Checker With Buzzer

A simple load checker that allows the cargo weight to be measured in 22 lb intervals is standard. If the load exceeds the set weight, the load checker sounds the buzzer to reduce the risk of exceeding the weight limit.

\* This system is a reference for the operator, therefore cannot be used for commercial purposes.



### Speedometer and Overspeed Warning Buzzer

The speedometer and the overspeed warning buzzer are equipped as standard. If the forklift's speed exceeds the set speed, the buzzer sounds to inform the operator he is traveling too fast.

\* The warning buzzer can be set at intervals of .5 mph.

### Key Cylinder Cover

This standard feature protects the key switch from dirt and dust, thus enabling the truck to work reliably in dusty environments.



### Locking Fuel Cap

A fuel cap with key is a standard feature that protects against stolen or contaminated fuel.



### Rear Assist Grip with Horn Button

When moving in reverse, a stable posture can be kept by grasping the rear assist grip. The horn can be operated with the finger tips while grasping the grip. This improves comfort in an application with long runs of reverse travel.



### ID Key Enables Identification of The Operating Record (Optional)

An ID key is available as an option to enable individual operator accountability. Since the truck can only be operated using a registered ID key, it also serves as an effective means of theft prevention.

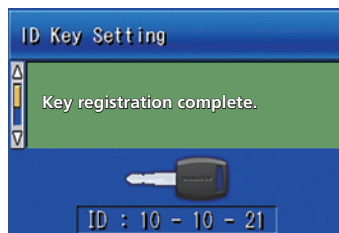

# COMFORT & EFFICIENCY

## Comfortable Operator Compartment Reduces Operator's Fatigue

### Full suspension seat

The new operator's seat has a wider seat surface, offers waist support and thus enables the operator to sit in a relaxed position. Thus, provides a comfortable work space and reduces operator's fatigue. In addition, an assist grip is mounted on the left side for easy entry and exit from the compartment.



### Upward exhaust muffler

An upward exhaust muffler prevents dust on the road surface from being blown up into the operator compartment area.



## Standard Equipment

Plastic overhead guard cover



Small diameter steering wheel (11.8")



Large assist grip



Tiltable steering column



Parking lever with release button



Overhead guard mounted headlights



Paper binder on engine hood



Wide step area



Pendulum type pedals



FH70-2 / FH80-2

# EQUIPMENT

## STANDARD EQUIPMENT

- U.L. Certified
- Komatsu Diesel Engine - EPA Tier 4 Final Compliant
  - Heavy duty high pressure common rail system
  - Air to air charge air cooling system
  - Sedimenter with priming pump
  - Electronic engine control system
    - Overheat prevention function
    - Auto engine warm-up function
    - Auto air preheat function
- Cyclone air cleaner (double element)
- Auto engine shutdown function
- Anti-restart ignition switch
- Variable engine output control function
- High efficiency fuel filter
- Variable displacement pump with CLSS
- Electronically-controlled HST
- Wet multi-disc brakes
- Parking brake with release button (with parking brake reminder caution)
- 99.4 in. high overhead guard
- Plastic overhead guard cover
- Neutral start function
- Speed limiter "Turtle" function
- Operator presence sensing system
- Key-off lift lock
- Full suspension seat w/ orange belt
- Fully hydrostatic power steering
- Tilttable steering column
- Small diameter steering wheel with spinner knob
- Steering knob synchronizer function
- Directional control lever
- Combination switch (turn signal lamp & lamp switch)
- Large LCD color display monitor
  - Engine coolant temperature indicator
  - Fuel gauge
  - Hour meter (SMR)
  - Preheating pilot indicator
  - Over speed caution
  - Parking brake indicator
  - Seat belt caution indicator
- Overspeed warning buzzer
- Paper binder on engine hood
- Rubber floor mat
- Compartment entry assist grip
- LED headlights & rear combination lights
- Upward exhaust pipe (Right side)
- 3-way control valve with port relief
- KOMTRAX wireless fleet management system
- Sealed DT type wiring harness connectors
- Flat face-to-face O-ring seals
- Fuel cap with key
- Key cylinder cover
- Load checker (equipped with a buzzer)
- Horn

### TIRES

- Front dual tires, pneumatic
- Rear steer tires, pneumatic

## OPTIONAL EQUIPMENT

- Assist grip with horn button on rear OHG leg
- 4-way control valve with port relief
- ID Key
- Steel cab w/ heater and defroster
- Steel cab w/ heater, defroster and air conditioner
- Inside rear view mirror
- Rear under mirror
- Tilt cylinder boots
- Power steering cylinder boots
- Cyclone air cleaner with pre-cleaner
- Removable radiator screen & chassis under carriage protection (screen)
- LED front working light(s)
- LED rear working light(s)
- LED rotating light
- Seat belt interlock function
- Mast tilt angle gauge
- Back-up alarm
- TIRES
  - Solid pneumatic tires
- FORKS
  - Optional fork lengths available
- ATTACHMENTS
  - Integral sideshifter
  - Fork positioner
  - Fork positioner with sideshift function



# SPECIFICATIONS

## SPECIFICATIONS

Characteristics	1.2	Model	Manufacturer's Designation		FH70-2	FH80-2	
	1.3	Power Type	Electric, Diesel, Gasoline, LPG, Cable		Diesel	Diesel	
	1.4	Operation Type			Sit Down	Sit Down	
	1.5	Rated Capacity	Q	Rated Capacity	lbs. (kg)	15,400 (7000)	18,000 (8000)
	1.6	Load Center	c	Rated Load Center	in. (mm)	24 (600)	24 (600)
	1.8	Load Distance	x	Front Axle Center to Fork Face	in. (mm)	24.0 (610)	26.0 (660)
	1.9	Wheelbase	y		in. (mm)	90.6 (2300)	90.6 (2300)
	2.1	Service Weight			lbs. (kg)	21,407 (9710)	24,868 (11280)
	Weight	2.2	Axle Loading	Loaded	Front	lbs. (kg)	32,860 (14905)
2.2.1		Rear			lbs. (kg)	3,979 (1805)	4,817 (2185)
2.3		Unloaded		Front	lbs. (kg)	9,028 (4095)	10,075 (4570)
2.3.1				Rear	lbs. (kg)	12,379 (5615)	14,793 (6710)
Tires	3.1	Tire Type			Pneumatic	Pneumatic	
	3.2	Tire Size	Front		8.25 - 15-14PR	8.25 - 15-18PR	
	3.3		Rear		8.25 - 15-14PR	8.25 - 15-18PR	
	3.5	Number of Wheel	Front/Rear (x=driven)		4x/2	4x/2	
	3.6	Tread, Front	b10		in. (mm)	60.6 (1540)	60.6 (1540)
	3.7	Tread, Rear	b11		in. (mm)	64.6 (1640)	64.6 (1640)
	Dimensions	4.1	Tilting Angle	a / b	Forward/Backward	degree	6/12
4.2		Mast Height, Lowered	h1	2-stage Mast	in. (mm)	101.8 (2585)	106.7 (2710)
4.3		Std. Free Lift	h2	2-stage Std. Mast, from Ground	in. (mm)	8.7 (220)	8.7 (220)
4.4		Std. Lift Height	h3	2-stage Std. Mast, from Ground	in. (mm)	118.1 (3000)	118.1 (3000)
4.5		Mast Height, Extended	h4	2-stage Std. Mast	in. (mm)	171.3 (4350)	171.3 (4350)
4.7		Height, Overhead Guard	h6		in. (mm)	99.4 (2525)	99.4 (2525)
4.19		Length, with Std. Forks	L1		in. (mm)	189.4 (4810)	193.5 (4915)
4.20		Length, to Fork Face	L2		in. (mm)	141.3 (3590)	145.5 (3695)
4.21		Width, at Tire	b1	Double	in. (mm)	80.7 (2050)	80.7 (2050)
4.22		Forks	s/e/l	Thickness x Width x Length	in. (mm)	2.6 x 5.9 x 48.0 (65 x 150 x 1220)	2.6 x 6.7 x 48.0 (65 x 170 x 1220)
4.23		Fork Carriage Class	ISO 2328, Type A/B/no			Class 4, A	Class 4, A
4.24		Width, Fork Carriage	b3		in. (mm)	66.5 (1690)	70.9 (1800)
4.31		Ground Clearance	m1	Under Mast	in. (mm)	9.3 (235)	10.0 (254)
4.32			m2	at Center of Wheelbase	in. (mm)	12.0 (305)	12.0 (305)
4.33	Aisle Width *	Ast	with L1000 x W1200 pallet	in. (mm)	211.8 (5380)	217.7 (5530)	
4.34		Ast	with L1200 x W800 pallet	in. (mm)	211.8 (5380)	217.7 (5530)	
4.35	Turning Radius	Wa		in. (mm)	131.9 (3350)	135.8 (3450)	
Performance	5.1	Travel Speed (FWD)	Loaded		mph (km/h)	14.0 (22.5)	14.0 (22.5)
			Unloaded		mph (km/h)	14.6 (23.5)	14.6 (23.5)
	5.2	Lifting Speed	Loaded		fpm (mm/s)	84.6 (430)	74.8 (380)
			Unloaded		fpm (mm/s)	98.4 (500)	88.6 (450)
	5.3	Lowering Speed	Loaded		fpm (mm/s)	94.5 (480)	90.6 (460)
			Unloaded		fpm (mm/s)	98.4 (500)	98.4 (500)
	5.6	Max. Drawbar Pull	Loaded 1.5 km/h, 3 min rating		lbs. (kN)	10,049 (44.7)	10,049 (44.7)
	5.8	Max. Gradeability	Loaded 1.5 km/h, 3 min rating		%	29	24
	5.10	Service Brake	Operation/Type			Foot/Hydraulic	Foot/Hydraulic
	5.11	Parking Brake	Operation/Control			Hand/Mechanical	Hand/Mechanical
	5.12	Steering	Type			FHPS	FHPS
	I.C Engine	6.4	Battery	Voltage/Capacity at 5-hour rating		V/Ah	2 x 12/72
7.1		Make/Model				KOMATSU	KOMATSU
						SAA4D95LE-6-C	SAA4D95LE-6-C
7.2		Rated Output, SAE net			kW	48.6	48.6
7.3		Rated RPM			min-1	2150	2150
7.3.1		Max. Torque, SAE net			HP (Nm/min-1)	68.6 (349/1400)	68.6 (349/1400)
7.4	No. of Cylinder/Displacement			Cu. In. (cm <sup>3</sup> )	4 / 199 (3260)	4 / 199 (3260)	
7.6	Fuel Tank Capacity			U.S. Gallons (L)	46.8 (177)	46.8 (177)	
Others	8.2	Relief Pressure for Attachment			PSI (MPA)	2,495 (17.2)	2,495 (17.2)
	8.2.1	Hydraulic tank Capacity			U.S. Gallons (L)	35.1 (133)	35.1 (133)
	8.7	Transmission				Hydrostatic	Hydrostatic

\* : VDI 2198 includes 200 mm clearance

## LOAD CAPACITY CURVE

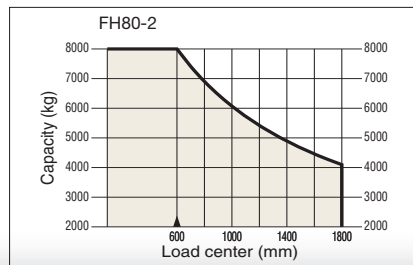
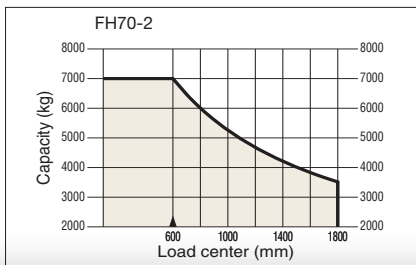

## DIMENSIONS

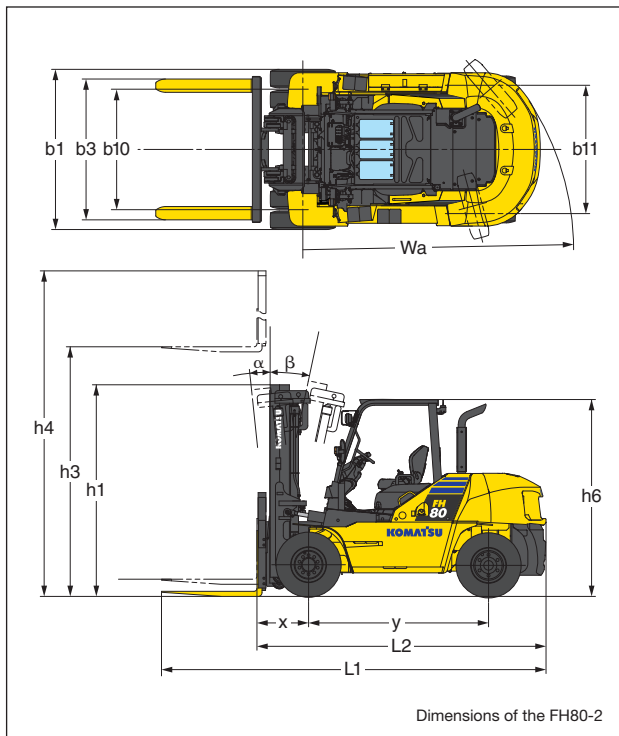

## AISLE WIDTH

Model	Length of Pallet in. (mm)	Width of Pallet - in. (mm)						
		31.5" (800)	35.4" (900)	39.4" (1000)	43.3" (1100)	47.2" (1200)	51.2" (1300)	55.1" (1400)
FH70-2	31.5" (800)	211.8" (5380)	211.8" (5380)	211.8" (5380)	211.8" (5380)	211.8" (5380)	211.8" (5380)	211.8" (5380)
	35.4" (900)	211.8" (5380)	211.8" (5380)	211.8" (5380)	211.8" (5380)	211.8" (5380)	211.8" (5380)	211.8" (5380)
	39.4" (1000)	211.8" (5380)	211.8" (5380)	211.8" (5380)	211.8" (5380)	211.8" (5380)	211.8" (5380)	211.8" (5380)
	43.3" (1100)	211.8" (5380)	211.8" (5380)	211.8" (5380)	211.8" (5380)	211.8" (5380)	211.8" (5380)	211.8" (5380)
	47.2" (1200)	211.8" (5380)	211.8" (5380)	211.8" (5380)	211.8" (5380)	211.8" (5380)	211.8" (5380)	211.8" (5380)
	51.2" (1300)	215.0" (5460)	215.0" (5460)	215.0" (5460)	215.0" (5460)	215.0" (5460)	215.0" (5460)	215.0" (5460)
	55.1" (1400)	218.9" (5560)	218.9" (5560)	218.9" (5560)	218.9" (5560)	218.9" (5560)	218.9" (5560)	218.9" (5560)
FH80-2	31.5" (800)	217.7" (5530)	217.7" (5530)	217.7" (5530)	217.7" (5530)	217.7" (5530)	217.7" (5530)	217.7" (5530)
	35.4" (900)	217.7" (5530)	217.7" (5530)	217.7" (5530)	217.7" (5530)	217.7" (5530)	217.7" (5530)	217.7" (5530)
	39.4" (1000)	217.7" (5530)	217.7" (5530)	217.7" (5530)	217.7" (5530)	217.7" (5530)	217.7" (5530)	217.7" (5530)
	43.3" (1100)	217.7" (5530)	217.7" (5530)	217.7" (5530)	217.7" (5530)	217.7" (5530)	217.7" (5530)	217.7" (5530)
	47.2" (1200)	217.7" (5530)	217.7" (5530)	217.7" (5530)	217.7" (5530)	217.7" (5530)	217.7" (5530)	217.7" (5530)
	51.2" (1300)	220.9" (5610)	220.9" (5610)	220.9" (5610)	220.9" (5610)	220.9" (5610)	220.9" (5610)	220.9" (5610)
	55.1" (1400)	224.8" (5710)	224.8" (5710)	224.8" (5710)	224.8" (5710)	224.8" (5710)	224.8" (5710)	224.8" (5710)

## MAXIMUM LOAD AND OVERALL HEIGHT OF MAST BY LIFTING HEIGHT

### ■ 2-Stage Free View Mast (Dual Drive Tires and 24" Load Center)

Maximum Fork Height: in. (mm)	Load Capacity - lbs.(kg)		Overall Height (Lowered / Extended) in. (mm)	
	FH70-2	FH80-2	FH70-2	FH80-2
118.1" (3000)	15,400 lbs. (7000)	18,000 lbs. (8000)	101.8" (2585) / 171.3" (4350)	106.7" (2710) / 171.3" (4350)
129.9" (3300)	15,400 lbs. (7000)	18,000 lbs. (8000)	107.7" (2735) / 183.1" (4650)	112.6" (2860) / 183.1" (4650)
137.8" (3500)	15,400 lbs. (7000)	18,000 lbs. (8000)	111.6" (2835) / 190.9" (4850)	116.5" (2960) / 190.9" (4850)
145.7" (3700)	15,400 lbs. (7000)	18,000 lbs. (8000)	115.6" (2935) / 198.8" (5050)	120.5" (3060) / 198.8" (5050)
157.5" (4000)	15,400 lbs. (7000)	18,000 lbs. (8000)	121.5" (3085) / 210.6" (5350)	126.4" (3210) / 210.6" (5350)
169.3" (4300)	15,400 lbs. (7000)	18,000 lbs. (8000)	129.3" (3235) / 222.4" (5650)	132.3" (3360) / 222.4" (5650)
177.2" (4500)	15,400 lbs. (7000)	18,000 lbs. (8000)	135.2" (3435) / 230.3" (5850)	140.2" (3560) / 230.3" (5850)
196.9" (5000)	15,400 lbs. (7000)	18,000 lbs. (8000)	147.0" (3785) / 250.0" (6350)	153.9" (3910) / 250.0" (6350)
216.5" (5500)	14,770 lbs. (6700)	16,975 lbs. (7700)	162.8" (4135) / 269.7" (6850)	167.7" (4260) / 269.7" (6850)
236.2" (6000)	14,330 lbs. (6500)	16,535 lbs. (7500)	172.6" (4385) / 289.4" (7350)	177.6" (4510) / 289.4" (7350)

### ■ 3-Stage Free View Mast (Dual Drive Tires and 24" Load Center)

Maximum Fork Height: in. (mm)	Load Capacity - lbs.(kg)		Overall Height (Lowered / Extended)	
	FH70-2	FH80-2	FH70-2	FH80-2
157.5" (4000)	14,110 lbs. (6400)	15,653 lbs. (7100)	94.5" (2400) / 212" (5385)	102.6" (2605) / 210.6" (5350)
177.2" (4500)	14,110 lbs. (6400)	15,653 lbs. (7100)	100.4" (2550) / 231.7" (5885)	108.5" (2755) / 230.3" (5850)
196.9" (5000)	13,889 lbs. (6300)	15,211 lbs. (6900)	108.3" (2750) / 251.4" (6385)	116.3" (2955) / 250.0" (6350)
216.5" (5500)	13,448 lbs. (6100)	14,110 lbs. (6400)	116.1" (2950) / 271.1" (6885)	124.2" (3155) / 269.7" (6850)
236.2" (6000)	12,125 lbs. (5500)	12,786 lbs. (5800)	124.0" (3150) / 290.7" (7385)	132.1" (3355) / 289.4" (7350)

# We're Close By

Komatsu Forklift U.S.A. has a dealer network covering all regions of the United States and Canada. So, it doesn't matter where you are located, a Komatsu Forklift U.S.A. dealer will be there ready to provide the quality service and solutions you need.

Visit [www.KomatsuAmerica.com](http://www.KomatsuAmerica.com) to locate your nearest dealer.

KOM1032-00

©2019 Komatsu America Corp.

Printed in USA

AD01(2.5M)OTP

08/20(EV-2)

**KOMATSU**<sup>®</sup>

*Note: All comparisons and claims of improved performance made herein are made with respect to the prior Komatsu model unless otherwise specifically stated.*

[www.KomatsuAmerica.com](http://www.KomatsuAmerica.com)

[www.KomatsuForkliftUSA.com](http://www.KomatsuForkliftUSA.com)

Komatsu America Corp. is an authorized licensee of Komatsu Ltd.

Materials and specifications are subject to change without notice. Photos may include optional equipment.

**KOMATSU**<sup>®</sup>, and KOMTRAX<sup>®</sup> are registered trademarks of Komatsu Ltd.

All other trademarks and service marks used herein are the property of Komatsu Ltd., Komatsu America Corp. or their respective owners or licensees.

FH70-2 / FH80-2