

KOMATSU

WA700-8



Photos may include optional equipment.

Wheel loader

Engine power

Gross : 775 HP (578 kW) @ 2,000 rpm

Net : 773 HP (577 kW) @ 2,000 rpm

Operating weight

214,069 lbs. (97,100 kg)

Standard bucket capacity

12 yd³ (9.2m³)

Horsepower

Gross : 775 HP (578 kW) @ 2,000 rpm

Net : 773 HP (577 kW) @ 2,000 rpm

Operating weight

214,069 lbs. (97,100 kg)

Productivity and economy features

- New engine technology and control system
- Redesigned Hensley bucket with Komatsu profile
- Increased lifting force
- Komatsu SmartLoader Logic
- Large-capacity torque converter with standard lock-up
- Large dumping clearance

Operator environment

- New operator seat with electronic pilot control (EPC) levers
- Advanced Joystick Steering System (AJSS)
- Automatic digging system
- Semi-auto approach and dump system

Visibility

- KomVision camera system
- Rear view monitoring system
- LED lighting package

Ecology

- Komatsu's U.S. EPA Tier 4 Final and E.U. Stage V emission regulations-compliant engine
- Technologies applied to new engine



Exceptional productivity and operator environment

Perfect four-pass match when loading 70 U.S. ton haul trucks

Durability and reliability features

- Common use of larger class WA wheel loader components
- Advanced frame and loader linkage

Information and Communication Technology (ICT)

- High resolution 7-inch color liquid crystal display (LCD) monitor
- Eco guidance operation
- Komtrax Plus

Maintenance features

- Swing-out type cooling fan and wide core radiator
- Machine immobilization switch
- Walkways with handrails
- Modular radiator core system
- Ground-level service center



Productivity and economy features

New engine technology and control system

Komatsu provides a powerful and economical U.S. EPA Tier 4 Final compliant engine with the latest emission control technologies. Designed for optimum power and a more efficient drive train, which can help improve fuel efficiency.

SAA6D170E-7
Engine rated output

Gross power 775 HP

* Compared with WA700-3 +8% UP

Gross torque 2,510 Ft • lbs

* Compared with WA700-3 +15% UP

Redesigned Hensley bucket with Komatsu profile

The redesigned bucket is engineered for enhanced productivity and durability. The bucket has a new shape with an increased radius and floor inclination that is designed to make it easier to fill with enhanced material retention. The spill guard design was adjusted to give operators greater visibility to the pile. Sweeper wings on either side of the bucket help to protect the front tires. Standard GET and wear package work to increase the durability to withstand harsh production environments.



Rated load

Increased by 6%

* Compared with WA700-3

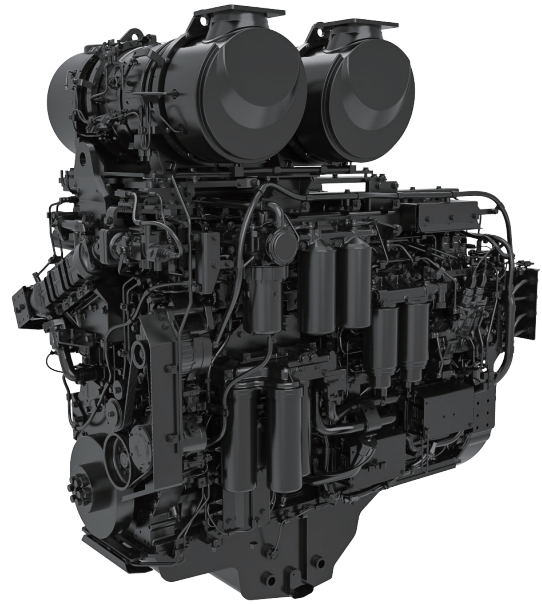

Advanced lifting force

An advanced lifting force designed to enhance productivity.

Lift force at boom top

47,435 lbf (Increased by 6%)

* Compared with WA700-3



Automatic transmission

The automatic transmission with an electronically controlled modulation valve (ECMV) automatically selects the proper gear based on travel speed, engine speed and other travel conditions. The ECMV engages the clutch smoothly to help prevent lag and shock when shifting gears. This system provides efficient machine operation and a comfortable ride. The transmission mode select system allows the operator to select manual shifting or automatic shifting.

Komatsu SmartLoader Logic

The WA700-8 is equipped with Komatsu SmartLoader Logic, an engine control system. This technology outputs the appropriate engine torque for each work phase. For example, engine torque needs are higher for digging in V-shape loading, but lower when driving with an empty bucket. This system works to optimize the engine torque for all applications to help minimize fuel consumption. Komatsu SmartLoader logic functions automatically and is engineered to help streamline operations while saving fuel and maintaining performance.

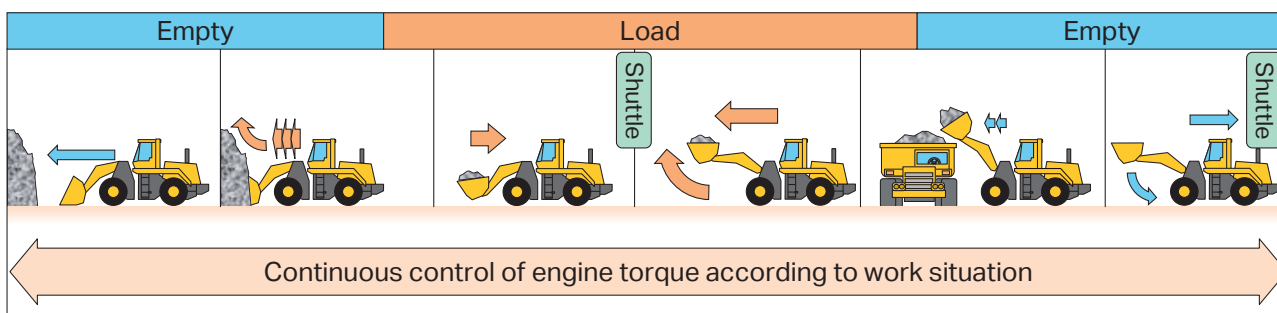

Variable displacement piston pump and closed-center loading sensing system (CLSS)

The variable displacement piston pump combined with the closed-center load sensing system delivers hydraulic flow when it is needed. The variable displacement piston pump destrokes to help minimize unnecessary hydraulic flow when not required, keeping hydraulic oil temperatures cool and promoting reduction in fuel consumption.

Advancement in fuel efficiency

The combination of new productivity-enhancing features and new fuel-saving features results in up to an 8% increase in fuel efficiency for the WA700-8 compared to the WA700-3.

Fuel efficiency(t/L)

Increased by 8%

* Compared with WA700-3

Tire slip control system

Tire slip control system help prevent tire slippage when digging. It works to reduce the traction force automatically when tire slip on one of the front wheels is detected.



Large-capacity torque converter with standard lock-up

The Komatsu-designed power train has a large capacity torque converter with standard lock-up designed for optimum efficiency. The WA700-8 provides advanced productivity in V-shape loading applications thanks to the large tractive effort. The lock-up function activates in 2nd and 3rd gears. The lock-up torque converter is effective for load and carry applications and when moving from a waiting area to working area. The lock-up torque converter combined with Komatsu SmartLoader Logic is designed to promote low fuel consumption and high travel speeds in load-and-carry applications.

Large dumping clearance

The WA700-8 was designed with ample dumping clearance for advanced haul truck matching. Also, an increased rated load capacity from previous models enables easy loading onto 70 U.S. ton class haul trucks in four passes.



* Compared with WA700-3 +140 mm UP

Operator environment



New operator seat with control levers

A new air suspension seat delivers enhanced support on rough roads and helps dampen machine vibrations, providing a comfortable ride for the operator. An integrated EPC lever console and advanced joystick steering lever move with the seat. The angle of the armrest is fully adjustable to promote optimum operator comfort. A 3-point seat belt, seat heater and ventilation are all standard equipment.



Variable traction control system

Machine rimpull can be set between 100% tractive effort down to 20% using the variable traction control system knob. Setting the correct rimpull to match underfoot conditions helps reduce tire slippage to promote enhanced tire life



Advanced Joystick Steering System (AJSS)

The AJSS allows steering and directional selection to be controlled by the operator's left hand. With the feedback function, the machine steering angle matches the angle of the joystick. The operability of the lever is improved compared with the WA700-3.



Throttle lock with auto deceleration

Low idle engine RPM can be set using the "throttle lock" switch located on the right-hand side of the console. Auto deceleration reduces the engine speed to 800 RPM automatically if no operator command is sensed after four seconds for added fuel savings.



Pillar-less large cab with ROPS/FOPS

The ROPS/FOPS certified cab is standard on the WA700-8. A wide pillar-less flat glass window is designed to provide excellent front visibility. Heated mirrors and rear window is designed to provide exceptional visibility in cold weather conditions. The interior of the cab is built to provide a quiet, low-vibration, dustproof, and comfortable operating environment. Walkways with handrails on the front and sides of the machine provide easy access to the cab.

ROPS (ISO 3471): Rollover Protective Structure
 FOPS (ISO 3449): Falling Objects Protective Structure



Trainer seat

A trainer seat with lap belt is standard equipment. It can be folded up when not in use.



LED room lamp and spot lamp

The LED lamps are standard and provide bright light to the operator.

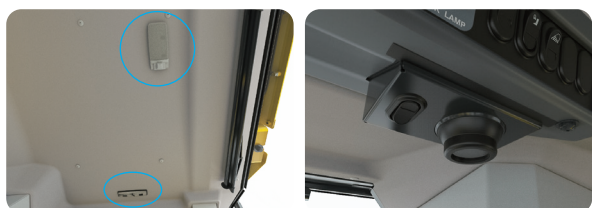

Radio with Bluetooth® and AUX inputs

The AM/FM radio is equipped with Bluetooth® and aux inputs allowing the operator to connect to the speakers in the cab.



Low noise design

The large cab is mounted with Komatsu's unique ROPS (ISO 3471)/FOPS (ISO 3449) viscous mounts. The low-noise engine, hydraulically driven fan, transmission pumps and hydraulic pumps are mounted with rubber cushions. The cab sealing has been improved to provide a quiet, low-vibration and comfortable operating environment.

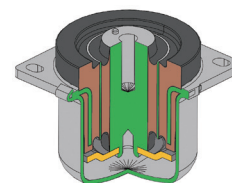

Noise level at operator's ear

75 dB(A) (ISO 6396)

Noise level at dynamic (outside)

114 dB(A) (ISO 6395)

Standard equipment

Storage area



Hot or cool box



Automatic air conditioner

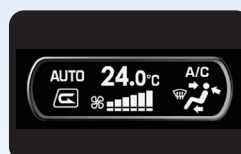

Side windshield wiper



Engine shutdown secondary switch



Parking brake switch



Operator environment

Automatic digging system

New automatic digging system actuates the bucket tilt and lifting operations by sensing the pressure applied to the work equipment, helping alleviate operator fatigue and optimize bucket load. The system can easily be activated or deactivated on the right-hand switch panel. It can be used independently of the semi-auto approach or semi-auto dump system. This feature can be used for both rock and loose materials by choosing between the two modes below.

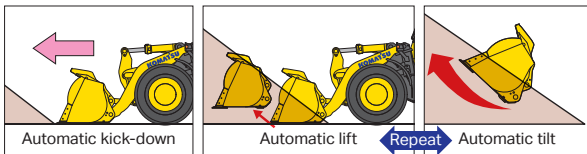

Work equipment shock reduction control

This is designed to reduce the stroke-end-shock in a bucket tilt or dump operation by decreasing the tilting or dumping speed automatically just before hitting the boom. This function helps enhance the durability of the work equipment and address operator fatigue. There are four settings that can be selected through the monitor panel: "low," "medium," "high" and "off".

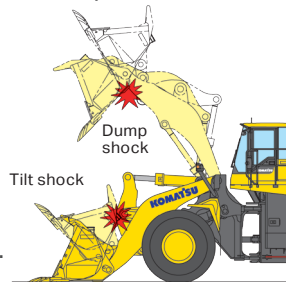

Semi-auto approach and dump system

This system is engineered to make dump truck loading operations easier and helps reduce operator fatigue. It automatically raises and lowers the lift arms according to preset travel distances. This system automates the bucket and the lift arms controls while dumping. Both the automatic digging, semi-auto approach system and semi-auto dump system can be activated or deactivated individually.

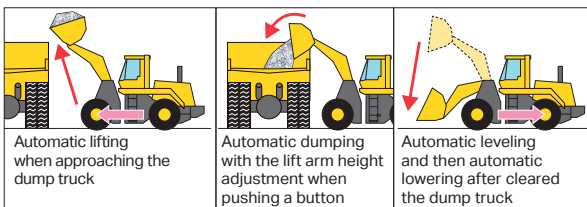

Auto kick-down control

Downshift and upshift between 1st and 2nd gear automatically without pushing the "kick-down" switch. This results in easy operation, helps increase the rimpull for enhanced bucket penetration and promotes productivity via shorter cycles.

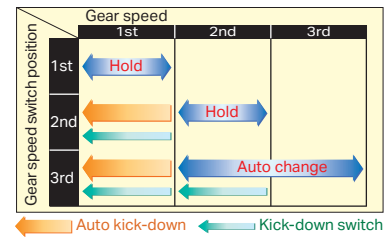

Remote bucket and boom positioner with shock reduction stop function

The stopping angle of the boom in both the raising and lowering direction, as well as the bucket stopping angle, can be set from the cab with the push of a button. Once the position is set, the bucket is smoothly stopped at the desired position.

Modulated clutch system

The modulated clutch adjusts the tractive effort using the left brake pedal from 100% to 20% of the torque converter output torque.

- Useful for a smooth speed reduction when approaching haul trucks
- Provides simple control of tire slippage
- Helps reduce shock when shifting from forward to reverse

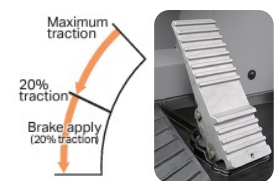

Electronically controlled suspension system

This system uses an accumulator that absorbs the shock in the boom arm, helping to give the operator a much smoother ride. It is engineered to control operator fatigue and material spillage during load-and-carry operations. The electronically controlled suspension system is speed-sensitive and engineered so that the boom cushioning function doesn't interfere with stationary digging.

Safety

KomVision camera system

A 270° "bird's eye view" of the machine can be displayed on the dedicated monitor within the console. Six cameras are installed at the sides, rear and front of the machine. The operator can select and display the camera by pressing the KomVision switches on the right-hand side switch panel.



The front camera image is useful for checking the space between the base of the boom and the ground. This feature aids in promoting operating awareness and used for tire cut prevention.

Rear view monitoring system

The operator can view the rear working area of the machine with a full color monitor located on the right side of the cab. This monitor can be always on or only on when in reverse. Visual guidelines can be added for additional guidance.

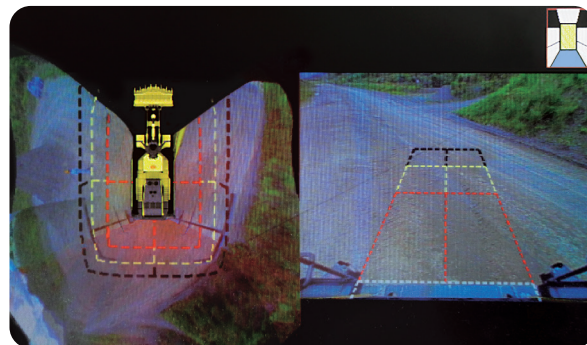
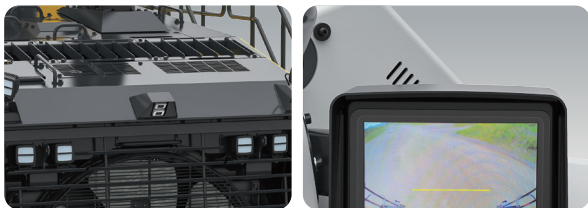

LED lighting package

22 LED work lamps provide excellent visibility in various working conditions. LED lamps promote long bulb life and easy maintenance.

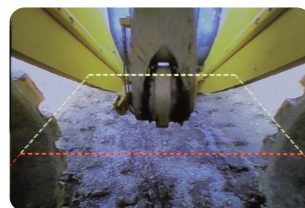

Ecology

Komatsu's U.S. EPA Tier 4 Final and E.U. Stage V emission regulations-compliant engine

Komatsu provides a powerful and economical U.S. EPA Tier 4 Final and E.U. Stage V compliant engine with the latest emission control technologies and fuel-saving features.

Technologies applied to new engine

- Komatsu Diesel Particulate Filter (KDPF)
- Variable geometry turbocharger (VGT) system
- Heavy-duty cooled exhaust gas recirculation (EGR) system
- Komatsu Closed Crankcase Ventilation (KCCV)
- High pressure common rail (HPCR) fuel injection system

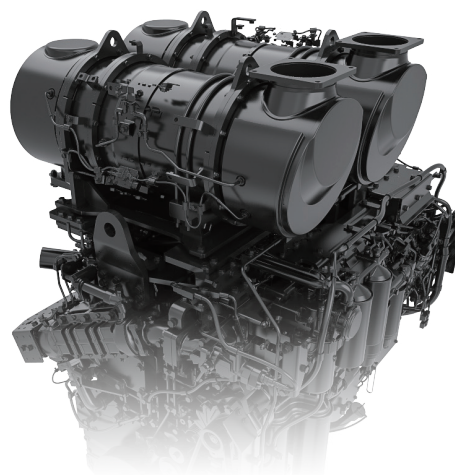

Durability and reliability features

Komatsu components

Komatsu manufactures the engine, torque converter, transmission, hydraulic units and electrical components on the WA700-8. Komatsu loaders are manufactured with an integrated production system under strict quality control.

Common use of larger class WA wheel loader components

Main components such as the transmission and axles are common to larger wheel loader models, for excellent reliability and durability.

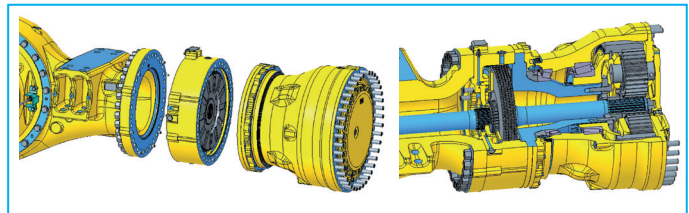
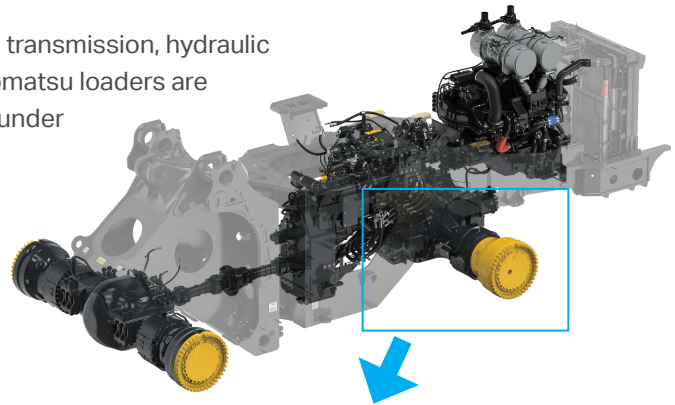

Divided type brake

Easy maintenance

The separate structure of the brake and final drive promotes ease of maintenance. Disassembly of the final drive is no longer necessary, which helps reduce maintenance time as well.

Heat dissipation performance

The brake has a thicker brake plate and more cooling oil around the brake than the conventional system. Combined with innovative oil circulation inside the axle, the brake is engineered for enhanced heat dissipation performance and brake durability.

Long-life frame and loader linkage

The front and rear frames and loader linkage system of the WA700-8 are designed to accommodate actual working loads. This design can increase machine life by 33% compared to the WA700-3.



Adjustment-free braking system

Wet multi-disk brakes and a fully hydraulic braking system promotes lower maintenance costs and enhanced reliability. The wet multi-disc brakes are fully sealed to help keep contaminants out, helping reduce wear and maintenance. The brakes are adjustment-free for even lower maintenance. Two independent hydraulic circuits provide hydraulic backup should one of the circuits fail, enhancing reliability. Fully hydraulic brakes mean no air system to bleed or water condensation in the system.

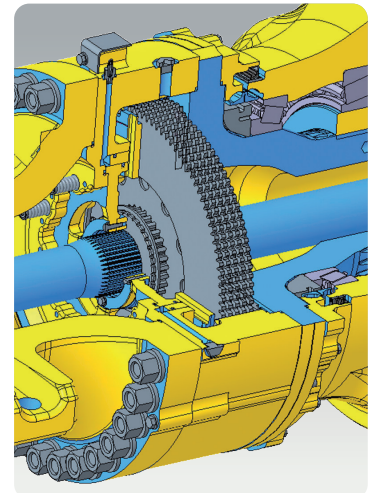

Information and communication technology (ICT)

High resolution 7-inch color LCD monitor

The machine monitor displays machine information and allows for various settings of the machine. The monitor is a 7-inch color LCD and displays maintenance information, operation records, ECO guidance records and more. The switch panel is used to select various screens and the air conditioner control screen. By using the switch panel, users can display various user menus on the LCD screen and adjust machine settings.

Machine monitor

- | | |
|---------------------------|---|
| 1 LCD unit | 8 Engine coolant temperature gauge |
| 2 LED unit | 9 Hydraulic oil temperature gauge |
| 3 Engine tachometer | 10 Torque converter oil temperature gauge |
| 4 Speedometer | 11 Fuel gauge |
| 5 ECO gauge | 12 Message pilot lamp |
| 6 Air conditioner display | 13 Pilot lamps |
| 7 Shift indicator | |

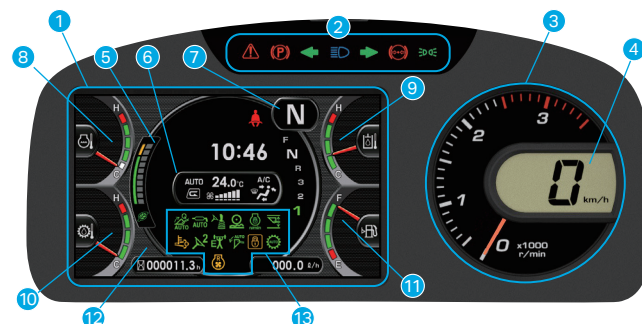

Switch panel

- 1 Air conditioner switches / Numerical key pad
- 2 Function switches

Visual user menu

Pressing the "menu" switch on the switch panel displays the user menu screen. The menus are grouped for easy function and use easy-to-understand icons that enable the machine to be operated fluently.

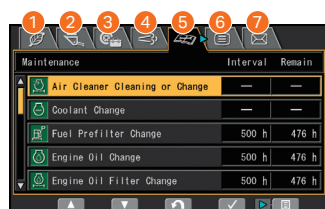

- 1 Energy saving guidance
- 2 Load meter
- 3 Machine setting and information
- 4 Aftertreatment devices regeneration
- 5 Maintenance
- 6 Monitor setting
- 7 Mail check

Machine monitor with troubleshooting function to minimize downtime

Various meters, gauges and warning functions are centrally arranged on the machine monitor. The monitor simplifies start-up inspection and promptly warns the operator with a lamp and buzzer if any abnormalities should occur. Abnormalities are indicated in four levels to identify the severity and urgency of response.



Energy saving operation ecology guidance

In order to support optimum operation, an easy-to-read "ecology gauge" is displayed on the machine monitor screen. In addition, the following five guidance messages are displayed for fuel saving operation.

- 1) Excessive engine idling event
- 2) Hydraulic relief pressure event
- 3) Dragging of brake event
- 4) Excessive stepping on accelerator event
- 5) Excessive digging event



The ECO guidance menu enables the operator to check the operation records, fuel consumption history and ECO guidance records by pushing the button. The records can be used to reduce the overall fuel consumption.

KOMTRAX Plus

Assists customer's equipment management and contributes to fuel cost cutting

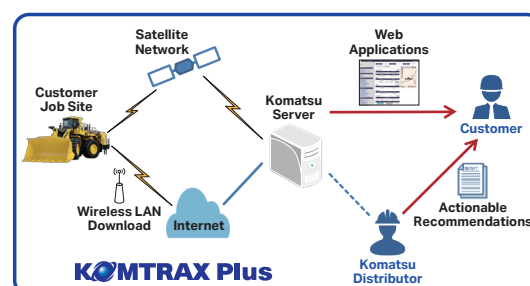

Maintenance features



Side-opening engine compartment doors

The wide access areas on both the left and right sides of the engine and standard LED engine bay lamps make daily maintenance easy. Large steps are located on each side of the frame for easy access.



Swing-out type cooling fan and wide core radiator

The cooling fan swings out for easy cleaning. The radiator with wide fin pitch helps reduce dust clogging.



Reversing fan

The engine cooling fan is driven hydraulically and can be reversed through the monitor.

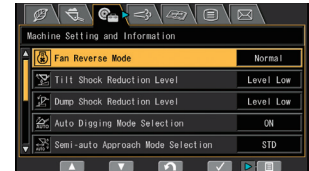

Battery and starter isolators

These are located on the left side of the machine at the primary ingress location. The battery isolator disconnects power when performing service work on the machine. The starter isolator provides the cab power but is engineered to prevent the engine from starting. Padlocks can be installed to lock out the machine.



“Machine immobilization” switch

This switch is located near the right-side battery box. When activated, the transmission, steering and work equipment are locked out. A status indicator lamp shows the state of the machine immobilization switch.

Walkways with handrails

Walkways with handrails on the front and side of the machine provide easy accessibility around the cab deck.



Engine compartment

The WA700-8 engine compartment is newly designed for optimal placement of maintenance-related items. These include the oil filler, oil level gauges, filters and aftertreatment devices for enhanced accessibility.



Rear full fenders

The rear full fenders with steps and handrails are standard on both sides of the machine. The fenders help protect the machine from materials that may be thrown by the tires and give technicians easy access to the engine compartment. The steps are ergonomically designed to support ingress and egress. In addition, the standard step light allows you to carefully go up and down at night.



Fast fuel system

The fast fill fuel coupler helps reduce fueling time. The refueling port is located on the rear left side of the loader and can be accessed from ground level.

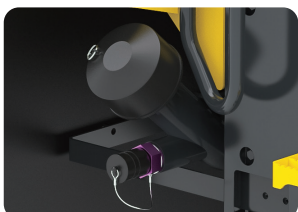

Modular radiator core system

The modular radiator core allows for individual cores to be replaced without the need to remove the entire radiator assembly.



Ground-level service center

Fill and drain quick coupler ports for the oils and coolant are accessible from the ground level. The auto-lubrication grease fill and live oil sampling ports are also located here to help significantly control maintenance time.



"Maintenance time caution lamp" display

Illuminates to indicate when the remaining time to maintenance becomes less than 30 hours*. Pressing the menu switch displays the maintenance screen.



Maintenance icon



Maintenance screen

Specifications

Engine

Model	Komatsu SAA6D170E-7
Type	Water-cooled, 4-cycle
Aspiration	Variable geometry turbocharged, and air to air aftercooled, cooled EGR
No. of cylinders	6
Bore	170 mm 6.69"
Stroke	170 mm 6.69"
Piston displacement	23.15 L 1,413 in³
Governor	All-speed, electronic
Engine power	
SAE J1995	Gross 578 kW 775 HP
ISO 14396	578 kW 775HP
ISO 9249 / SAE J1349	Net 577 kW 773 HP
Rated rpm	2,000 rpm
Fan drive method for radiator cooling	Hydraulic
Fuel system	Direct injection
Lubrication system	
Method	Gear pump, force-lubrication
Filter	Full-flow type
Air cleaner	Dry type with double elements, plus dust indicator

* U.S. EPA Tier 4 Final and EU Stage V emissions certified.

Transmission

Type	Automatic powershift transmission			
Torque converter	3-elements, 1-stage, 1-phase, with lock-up clutch			
Measured with 45/65R39				
		1st	2nd	3rd
Lock-up OFF	Forward	7.6 km/h (4.7 mph)	13.5 km/h (8.4 mph)	23.2 km/h (14.4 mph)
	Reverse	7.9 km/h (4.9 mph)	13.5 km/h (8.4 mph)	24.0 km/h (14.9 mph)
Lock-up ON	Forward	-	13.5 km/h (8.4 mph)	25.9 km/h (16.1 mph)
	Reverse	-	13.5 km/h (8.4 mph)	26.9 km/h (16.7 mph)

Axles and final drives

Drive system	Four-wheel drive
Front	Fixed, full-floating
Rear	Center-pin support, full-floating
Reduction gear	Spiral bevel gear
Differential gear	Conventional type
Final drive	Planetary gear, single reduction

Brakes

Service brakes	Hydraulically actuated, wet multiple-disc brakes actuate on four wheels
Parking brake	Wet multiple-disc brake
Secondary brake	One of dual service brake circuits is commonly used.

Steering system

Type	Articulated type, full-hydraulic power steering
Steering angle	40° each direction
Minimum turning radius at the center of outside tire	9050 mm/29' 8"

Hydraulic system

Steering system:	
Hydraulic pump	Piston pump
Capacity	2 x 157.5 L/min 41.6 gal/min at rated rpm
Relief valve setting	31.3 MPa 320 kgf/cm ² 4,540 psi
Hydraulic cylinders:	
Type	Double-acting, piston type
Number of cylinders	2
Bore x stroke	150 mm x 587 mm 5.9" x 23.1"
Loader control:	
Hydraulic pump	Piston pump
Capacity	4 x 224 L/min 59.2 gal/min at rated rpm
Relief valve setting	34.3 MPa 350 kgf/cm ² 4,975 psi
Hydraulic cylinders:	
Type	Double-acting, piston type
Number of cylinders – bore x stroke:	
Lift cylinder	2 – 225 mm x 1360 mm 8.9" x 53.5"
Bucket cylinder	1 – 280 mm x 824 mm 11" x 32.4"
Control valve	Spool type
Control positions:	
Boom	Raise, hold, lower, and float
Bucket	Tilt-back, hold, and dump
Hydraulic cycle time	
Raise (Rated load in bucket)	7.4 s
Dump (Empty)	2.8 s
Lower (Empty)	4.4 s

Service refill capacities

Cooling system	221 L/ 58.4 US gal
Fuel tank	1420 L/ 375.1 US gal
Engine	86 L/ 22.7 US gal
Hydraulic system	833 L/ 220.1 US gal
Axle front	340 L/ 89.8 US gal
rear	340 L/ 89.8 US gal
Torque converter and transmission	230 L/ 60.8 US gal

Bucket selection guide

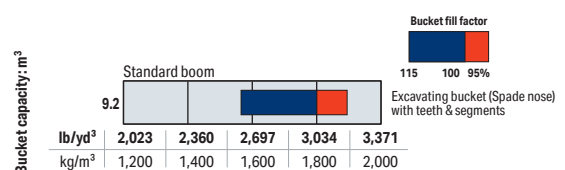

Dimensions

Measured with 45/65 R39 (L-5) tires, ROPS (ISO 3471)/FOPS (ISO 3449) cab

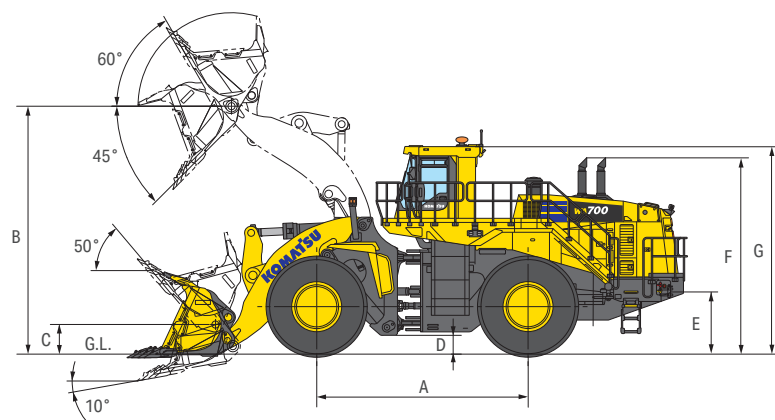

Standard boom

Overall width without bucket	3250 mm 10' 8"
Width over tires	4380 mm 14' 4"
A Wheelbase	5340 mm 17' 6"
B Hinge pin height, max. height	6265 mm 20' 7"
C Hinge pin height, carry position	750 mm 2' 6"
D Ground clearance	475 mm 1' 7"
E Hitch height	1570 mm 5' 2"
F Overall height, top of the stack	4960 mm 16' 3"
G Overall height, ROPS (ISO 3471) cab	5240 mm 17' 2"

Standard boom Excavating bucket Spade nose Teeth and segments

Bucket capacity:	Heaped	9.2 m ³ 12 yd ³	
	Struck	8.0 m ³ 10.5 yd ³	
Bucket width		4710 mm 15' 5"	
Bucket weight		16560 kg 36,509 lbs.	
Dumping clearance, cutting edge		4540 mm 14' 11"	
Dumping clearance, teeth		4180 mm 13' 9"	
Reach, cutting edge		2080 mm 6' 10"	
Reach, teeth		2325 mm 7' 8"	
Operating height (Fully raised)		8625 mm 28' 4"	
Overall length		14130 mm 46' 4"	
Minimum turning radius (Bucket at carry, outside corner of bucket)	Full lever	Outside	10930 mm 35' 10"
		Center of outside tire	9460 mm 31' 0"
	Maximum articulate	Outside	10550 mm 34' 7"
		Center of outside tire	9050 mm 29' 8"
Digging depth (At the end of tooth)	0°	240 mm 0' 9"	
	10°	670 mm 2' 2"	
Static tipping load	Straight	68400 kg 150,796 lbs.	
	40° full turn	59100 kg 130,293 lbs.	
Breakout force	Boom	501 kN (51100 kgf) 36,509 lbf	
	Bucket	615 kN (62700 kgf) 138,230 lbf	
Operating weight		97100 kg 214,069 lbs.	

All dimensions, weights, and performance values based on ISO 7131 and 7546 standards.

Static tipping load, operating weight and overall length shown include lubricant, coolant, full fuel tank, ROPS (ISO 3471) cab and operator.

Machine stability and operating weight affected by counterweight, tire size, and other attachments.

Apply the following weight changes to operating weight, static tipping load and overall length.

Equipment

Lighting system

Access stair lamp, LH side, LED	●
Directional signal	●
Engine bay lamp, LED	●
Hazard lamps	●
Headlamps, LED	●
Front work lamps, LED	●
Rear corner additional work lamp, LED	●
Rear work lamps, LED	●
Side work lamps, LED	●
Stop and tail lamps and turn signal lamps, LED	●

Cab

2 x DC12V electrical outlets	●
Advanced joystick steering system	●
Auto air conditioner	●
Ashtray	●
Cigarette lighter	●
Color multi-monitor	●
Cup holder	●
Electronic pilot control (EPC)	●
Floor mat	●
Front wiper (with washer and intermittent)	●
Operator seat with 3-point seat belt, ventilation, air suspension type	●
Radio: AM/FM with AUX terminal, USB port for charging and	●
Rear defroster (electric)	●
Rear wiper (with washer and intermittent)	●
Room mirror	●
Room lamps, LED	●
ROPS(ISO 3471)/FOPS (ISO 3449)	●
Space for lunch box	●
Spot lamp, LED	●
Steel cab included front, rear and side wiper with windshield washer	●
Sun shades (front and rear), retractable type	●
Sun visor (front)	●
Trainer seat with 2-point seat belt	●

General equipment

Back-up alarm	●
Beacon lamp	●
Emergency stop switch	●
Engine shutdown secondary switch	●
Hand rails for platform	●
Horn, electric	●
KomVision camera system	●
Machine lock out system	●
Parking brake, electric	●
Rear view monitoring system	●
Secondary brake	●
Secondary steering (ISO 5010)	●
Service brakes, wet disc type	●

Engine

Air cleaner, Dry type with double elements, plus dust indicator	●
Alternator, 24 V/140 A	●
Bio diesel fuel, B20	●
Engine, Komatsu SAA6D170E-7	●
KDPF	●
Maintenance free batteries, Large capacity, 4 x 12 V/160 Ah	●
Starting motor, 2 x 24 V/11 kW	●

Others

2-way engine power mode	●
3rd gear prohibition and speed limit control	●
45/65R39(L-5) without tire	●
Auto greasing system	●
Automatic digging system	●
Automatic shift transmission	●
Battery and starter Isolators	●
Boom positioner with kick-out	●
Brake cooling system	●
Brake oil thermometer display	●
Bucket positioner	●
Circuit breaker	●
ECO guidance, ECO gauge	●
Electronically controlled suspension system (ECSS)	●
Engine RPM set system with auto deceleration	●
Engine starter disconnect switch	●
Fire extinguisher stand provision	●
Front fenders	●
Fuel pre-filter with water separator	●
Heated mirrors	●
Hydraulic-driven fan with reverse rotation	●
Inline filters, steering and hydraulic	●
Auto idle shutdown	●
Komatsu SmartLoader Logic	●
KomTrax Plus	●
KOWA sampling port	●
Lift cylinders and bucket cylinder	●
Load meter system	●
Modulation clutch	●
Modular radiator core	●
Power train guard	●
Quick coupling for fuel tank	●
Radiator mask, swing out	●
Rear access stair with handrail	●
Semi-auto approach and dump system	●
Service center, engine, transmission, break oil, and coolant	●
Starter receptacle	●
Sweeper wing	●
Tire slip control	●
Wall digging prevention control system	●
Work equipment shock reduction control	●

Further equipment on request

- Standard equipment
- Optional equipment

Product designs, specifications and/or data in this document are provided for informational purposes only and are not warranties of any kind. Product designs and/or specifications may be changed at any time without notice. The only warranties that apply to sales of products and services are Komatsu's standard written warranties, which will be furnished upon request.

Komatsu and other trademarks and service marks used herein are the property of Komatsu Ltd., Komatsu America Corp., Komatsu Mining Corp., or one of their affiliates, or the respective owners or licensees.

KOMATSU

komatsu.com

