

# KOMATSU<sup>®</sup>

## C124

Forestry Quality™

C124

HEAD



## Highly productive medium-sized head

The Komatsu C124 is a head that delivers – day in day out. Despite its sturdy frame design, the C124 is a lightweight head that with a tilt angle of a full 40 degrees offers effective feeding and reduced strain on the head body when logging in hilly terrain. Komatsu's four feed roller solution provides multiple points of contact between stem and head. The result is low friction and high net tractive force, which means low energy consumption. The four feed roller solution combined with concave rollers also creates good conditions for high measurement accuracy.

One major advantage of the C heads is that the stem is held by the feed rollers. The feed rollers centre the stem, which ensures efficient feeding, while the low clamping pressure reduces friction.

The C124 has cast delimiting knives, which means high dura-

bility. The new mounts for the diameter sensors also enhance this durability.

The Constant Cut saw unit guarantees the right saw speed throughout the entire cutting cycle and prevents the chain from being over-revved. As a result, the risk of splitting decreases and safety increases. Moreover, the saw unit's hydraulic design provides good access around the head valve while a unique saw unit controller ensures good capacity and good hydraulic component durability.

As an option, you can add working lights to the saw box, which helps increase productivity by allowing faster stem collaring and a reduced risk of sawing rocks. The Komatsu C124 can be fitted to most of our harvester models.

# TECHNICAL DATA

# C124

## Komatsu C124, highlights

- Cast delimiting knives for increased durability
- Strong and sturdy frame design for high net lifting force
- Four feed rollers for high net tractive force and fast feeding
- Four moving delimiting knives for good stem holding
- Large tilt angle simplifies work in steep terrain
- Good stem holding for exact length measurement
- Constant Cut saw unit increases productivity and safety
- The Eco-GLS lubrication system (optional) lowers lubricant consumption, reduces fuel consumption, eliminates oil mist and lessens environmental impact
- Multi-tree handling function as an option
- Easily accessible service points for simple daily maintenance
- Working lights on the saw box for easier stem collaring and reduced risk of sawing rocks

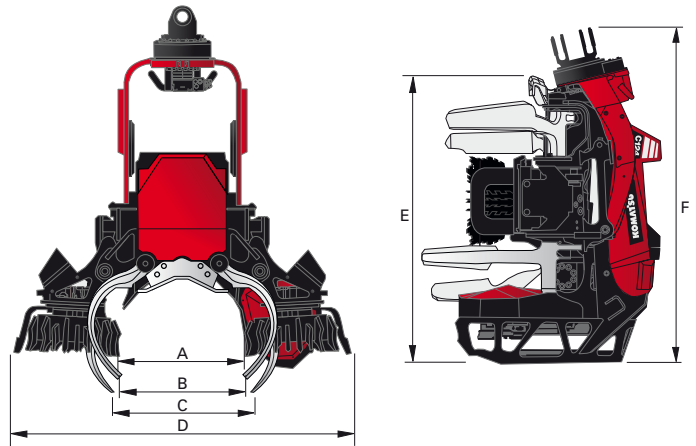

Weight:	from 1,225 kg
Feeding speed:	0-5 m/s
Feed force, gross (feed roller dependent):	625 cc: 23.7 kN 750 cc: 28.3 kN
Feed roller, type:	Steel
Delimiting knives, total:	5
Delimiting diameter, tip-to-tip:	460 mm
Saw bar length:	75 cm or 82.5 cm
Saw motor:	19 cm <sup>3</sup> /rev.
Felling diameter, theor. max.:	650 mm
Requisite max. hydraulic flow (feed roller dependent):	625 cc: 255 l/min 750 cc: 300 l/min
Requisite max. hydraulic pressure:	28 MPa

<b>A</b> Feed roller opening, max.	650 mm
<b>B</b> Opening upper knives, max.	625 mm
<b>C</b> Opening lower knives, max.	700 mm
<b>D</b> Width, max.	1,750 mm
<b>E</b> Height to vertical knife	1,595 mm
<b>F</b> Height including rotator	1,730 mm

### NOTES

The specifications describe possible equipment, not which equipment is standard or optional. Standard and optional equipment varies between countries. Your sales representative has an up-to-date list of what is included. Weights are based on the equipment specified in the basic specification. Specifications and designs are subject to alteration without prior notice.



### ZONE OF APPLICATION

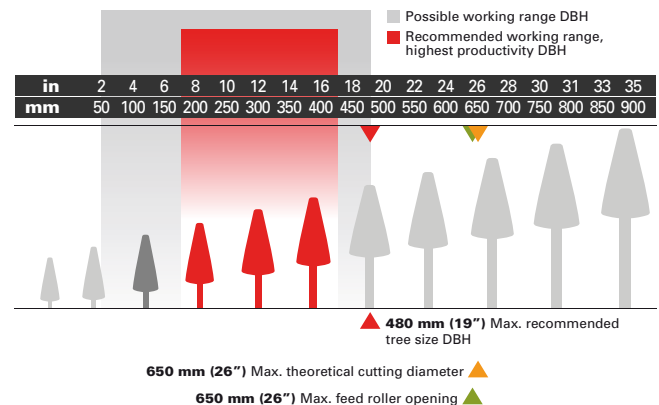

## KOMATSU

Komatsu Forest AB  
www.komatsuforest.com