

# KOMATSU<sup>®</sup>

## C202

Forestry Quality™

C202

HARVESTING HEAD



## Strong, durable, and highly productive

The new C202 is an extremely high-quality, highly productive, and robust head. The quality and the durability can be seen in everything from the sturdy frame and saw units to the stable attachments and reliable hydraulics. Everything to optimize reliability, service life, and ease of service.

What's more, this is a head with a myriad of options. You can, for example, opt for a vertical knife with a skid tip and thereby improve performance when working with crooked trees. If your base machine is a forestry excavator, you have the option of equipping the head with a sprocket,

saw bar, and chain for  $\frac{3}{4}$ " pitch (standard if the base machine is a wheeled harvester). You decide.

Another reason to choose the C202 is its superb measurement accuracy. The Maxi control and information system provides full control and automatically takes care of everything from gripping force to length and diameter measurements. So, if you want a head that's as durable and sturdy as it is technically advanced, choose the Komatsu C202!

# TECHNICAL DATA

# C202

## Komatsu C202, highlights

- **Sturdy, robust design**
- **Extremely durable**
- **Powerful control and information system**
- **Easy to service**
- **Long service life**
- **Sturdy frame, saw unit, feed roller arm, and knife cylinder designs**
- **Stable hood attachment**
- **Expander pins on feed rollers and delimiting knives**
- **Equipped with a sprocket, saw bar, and chain for 404" pitch (wheeled base machine)**
- **¾" pitch equipment available as an option for forestry excavators**
- **Vertical knife with skid tip (optional)**

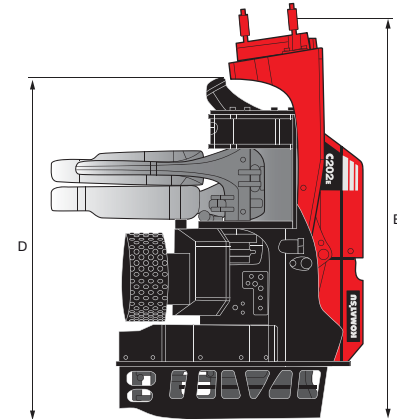
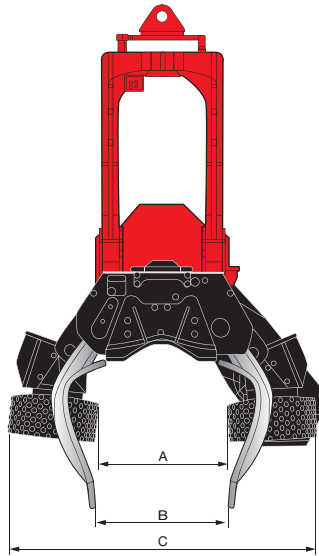

Dry weight:	2,060 kg (4,542 lb)
Feed rate (motor dependent):	0–4/4.5 m/s (0–13.1/14.8 ft/s)
Feed force, gross (motor dependent):	36.3/39.6 kN (8,161/8,902 lbf)
Feed wheel type:	Steel rollers
Delimiting knives, max. number:	3
Delimiting diameter, tip-to-tip:	560 mm (22")
Saw bar:	84 cm (33")
Saw motor:	30 cm <sup>3</sup> /rev
Felling diameter, theoretical max:	700 mm (27.6")
Requisite max. hydraulic flow:	330 l/min (87 gpm)
Requisite max. hydraulic pressure:	30 MPa (4,351 psi)

<b>A</b> Roller opening, max.	650 mm (25.6")
<b>B</b> Opening forward knives, max.	670 mm (26.4")
<b>C</b> Width, max.	1,645 mm (64.8")
<b>D</b> Height to vertical knife	1,700 mm (66.9")
<b>E</b> Height with rotator	1,995 mm (78.5")

NB: Refers only to one of several possible configurations and the head's weight is dependent on equipment options.

### EQUIPMENT OPTIONS

Standard and extra equipment are market-dependent and vary between countries. Your sales representative has an up-to-date list of what is included.

Technical data/dimensions vary depending on optional equipment selected. Specifications and designs are subject to alteration without prior notice. Photos, diagrams, and figures do not always show the standard configuration.



### ZONE OF APPLICATION

