

KOMATSU

4800XPC

Electric mining shovel
General specifications



More productive



Lower costs



Less emissions



Nominal payload

135 st. / 123 mt.

Dipper capacity

86-92+ yd³ / 25.5 m³.

Productivity

9,712 – 12,950 tonne/hr.

P&H

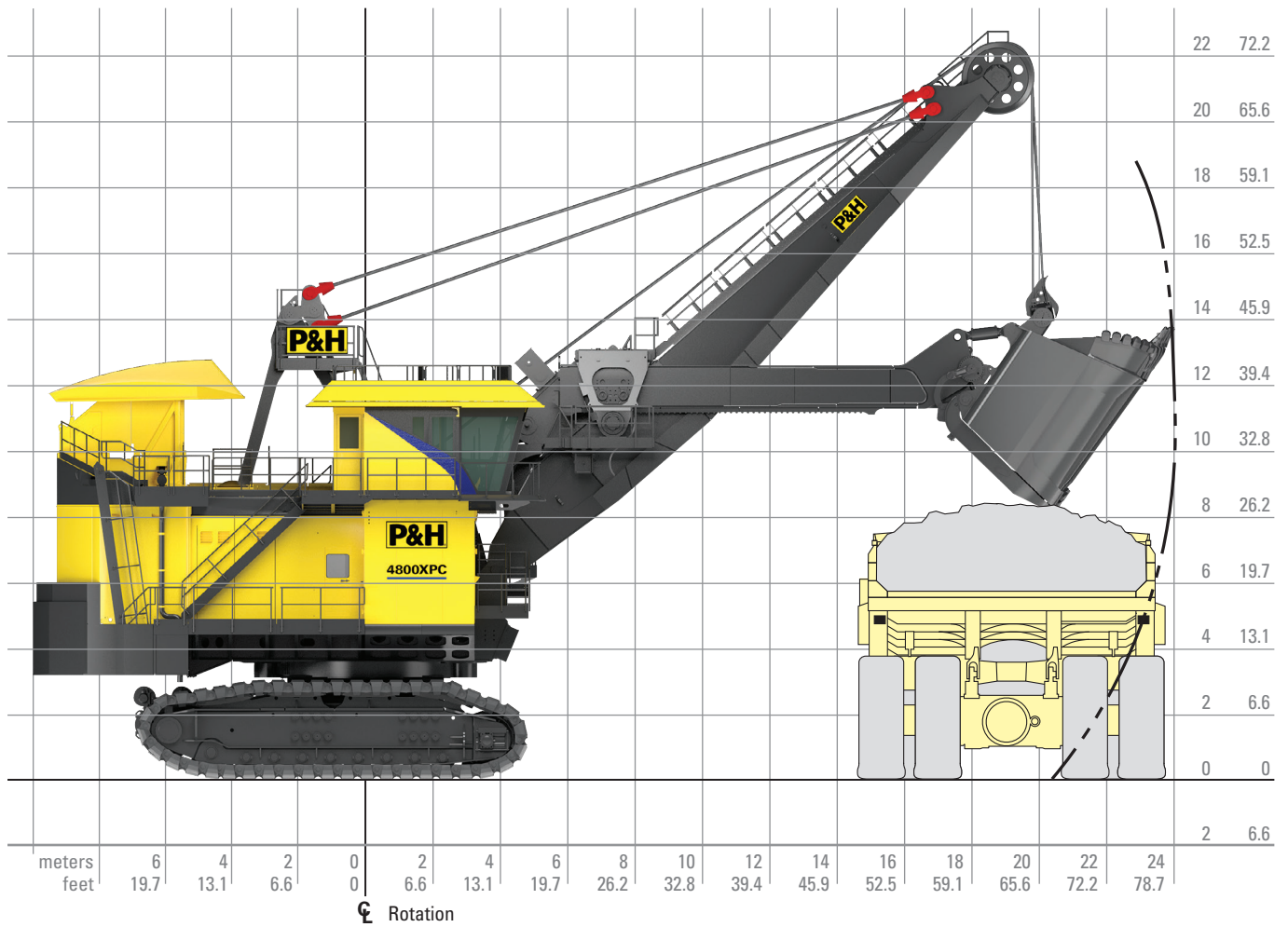

Working ranges

Height of cut	18.9 m.	62 ft. 2 in.
Radius of cut	24.0 m.	78 ft. 7 in.
Max dump reach (furthest distance to center of truck)	19.4 m.	63 ft. 6 in.
Dumping height* (door open)	10.8 m.	35 ft. 7 in.
Floor level radius	16.2 m.	53 ft. 3 in.
Tail swing radius	9.9 m.	32 ft. 7 in.
Operator eye level	10.1 m.	33 ft. 1 in.

Capacity

Nominal payload*	122.5 mt.	135 st
Nominal dipper capacity SAE struck	65.7-70.3 m ³ .	86-92 yd ³ .
Rated suspended load	223.6 mt.	246.5 st.
Optimum truck size (360 mt (400 st) truck shown)	360 mt.	400 st.

*Payload and dipper capacity are dependent on many factors. Contact Komatsu Mining for an analysis of your specific application.

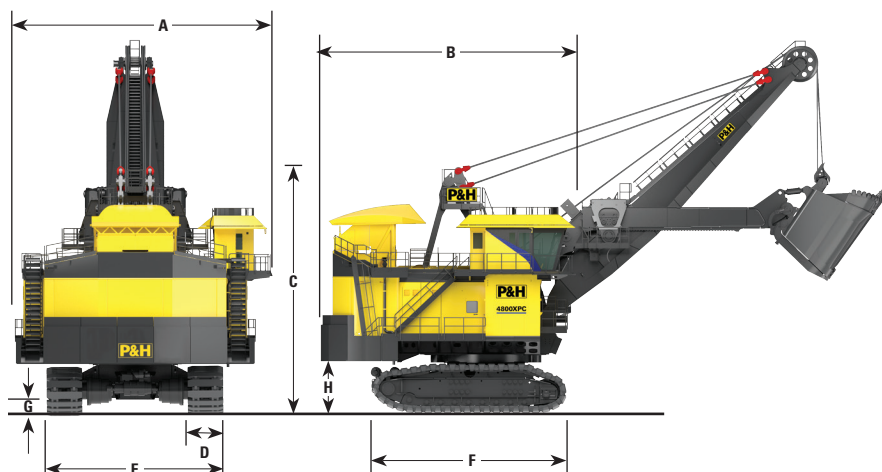

Overall dimensions

A	Width	15.0 m.	49 ft. 3 in.
B	Length	15.2 m.	50 ft. 0 in.
C	Height over gantry	14.7 m.	48 ft. 2 in.
D	Width of crawler shoes	2540 mm.	100 in.
E	Width of crawlers (100")	11.1 m.	36 ft. 5 in.
F	Length of crawlers	11.5 m.	37 ft. 8 in.
G	Ground clearance	0.7 m.	2 ft. 2 in.
H	Height — ground to bottom of counterweight slabs	3.3 m.	10 ft. 9 in.

Power requirements

Supply voltage*	7200 or 13800V. 3 Phase, 60 Hz.	6000, 6600, 7200 or 11000V. 3 Phase, 50 Hz.
Supply transformer	(Minimum) 3750 kVA.	
Minimum short circuit VA available at shovel	30 MVA.	

*Voltage per customer requirements

Adaptive controls technology

Smart control and application of power to improve payload and digging performance of machine.

Increases shovel digging power without sacrificing life.

Reduces loading from non productive impacts.

Decreases operator fatigue by limiting rocking motions of the shovel especially in difficult digging conditions.

Swing

Three modular P&H planetary gear cases of proven design and a single piece forged swing gear transmit torque for fast cycle times.

Spring-set air release disc brakes – one per motor.

Splash lube filtration system.

Propel

Propel on demand provides rapid transfer to propel mode. Rapid transfers allow frequent positioning of the shovel to the bank resulting in faster cycle times and more efficient digging.

Two rugged P&H planetary gear cases of proven design independently transmit torque to the drive sprockets, producing the tractive effort required for fast, efficient propel and positioning operations.

P&H brand Delta drive low tension sprocket drive system with heavy duty cast crawler shoes.

Spring-set air release disc brakes – one per motor.

Crowd

Twin low inertia AC motors minimize shock loading and boom jacking.

Direct drive crowd eliminates belt maintenance for improved responsiveness.

Modular crowd motors with integral pinions provide for simplified motor replacement.

Two input pinions share load for extended life.

Dual spring-set air release brakes for reliable redundant operation.

Hoist

All gearing housed in single enclosed gear case with filtered and cooled oil fed to all bearings in addition to splash lubrication for reliable operation and ease of maintenance.

Large 68" diameter hoist drum for extended rope bending life. Ferrule becket system and dual electric tuggers are standard for efficient rope change.

Spring-set air release disc brakes – one per motor.

Hoist rope fleeting sheave protects rope from excessive oscillation.

Product designs, specifications and/or data in this document are provided for informational purposes only and are not warranties of any kind. Product designs and/or specifications may be changed at any time without notice. The only warranties that apply to sales of products and services are Komatsu's standard written warranties, which will be furnished upon request.

Komatsu and other trademarks and service marks used herein are the property of Komatsu Ltd., Komatsu America Corp., Komatsu Mining Corp., or one of their affiliates, or the respective owners or licensees.

© 2020 Komatsu Mining Corp. All rights reserved.

EN-4800XPCSP01-0921-V2



KOMATSU

mining.komatsu