

AX50



KOMATSU[®]



The Forklift With Proven Ability.™

PNEUMATIC TIRE FORKLIFTS

3,000 – 3,500 LBS. CAPACITY | GAS AND LPG



ENGINEERING BIG PERFORMANCE REQUIRED A FOCUS ON THE SMALL DETAILS.

GREAT DESIGN starts on the smallest level. And with the Komatsu AX50, no detail has been overlooked. Building on our 90-year history of superior engineering, the AX50 delivers improved performance and unbeatable strength for your most demanding applications. The forklifts are available in 3,000- and 3,500-pound capacities. And both deliver on the qualities you've come to count on in a Komatsu — high performance, low maintenance requirements, total operator comfort and excellent reliability.



ADVANCED EMISSION CONTROLS CREATE A CLEANER ENVIRONMENT

THE AX50 SERIES uses advanced Clean Air Technology to bring exhaust emissions well below regulations for gasoline and LPG engines set by the U.S. Environmental Protection Agency (EPA).

Emission reductions come in part from a Engine Control Module (ECM) used in both gasoline and LPG engines. The ECM more accurately regulates air-fuel ratios to deliver optimum combustion while producing exceptionally low emissions levels.

The AX50 also reduces environmental sound levels because they produce high operating torque at low engine speeds. All these AX50 features work together to provide a more pleasant and productive environment for everyone in the work area.

GET LOW FUEL CONSUMPTION & DUAL-FUEL FLEXIBILITY

The AX50 engine uses an Electronic Concentrated Control System (ECCS) and Sophisticated Optimized Fuel Injection System (SOFIS) for low fuel consumption. Gasoline versions use multi-port fuel injection and LPG engines use single-port, throttle body fuel injection. The AX50 is also available with a dual-fuel system that offers additional job-site flexibility by providing optimum performance on either fuel.

MODELS

AX50 Series

LPG Engine Forklifts, Dual-Fuel
Engine Forklifts
3,000 lbs. / 3,500 lbs.



PUT YOUR OPERATORS IN THE KOMFORT ZONE™

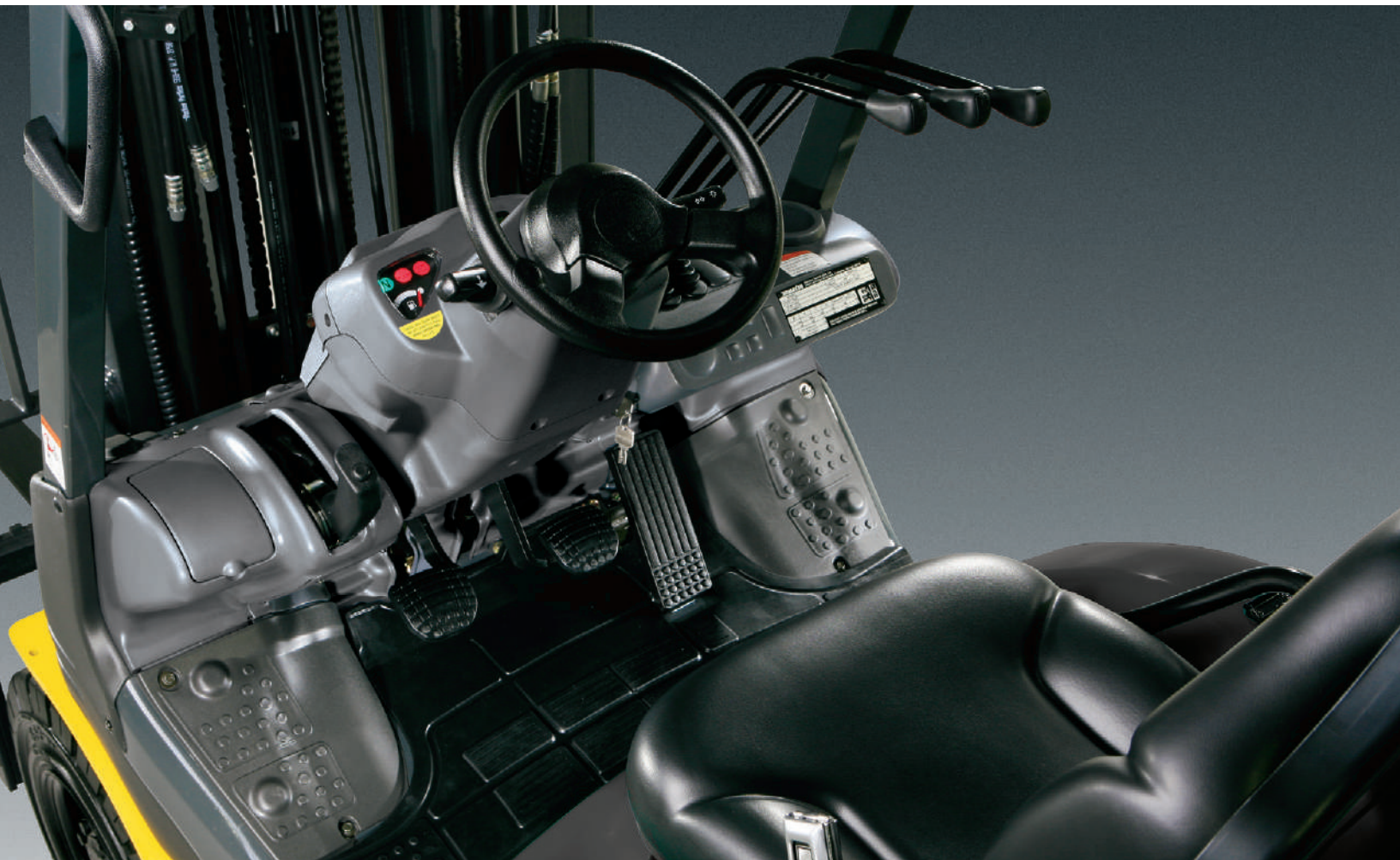

DESIGNED FOR COMFORT AND CAPABILITY

The influence of Komatsu's construction division is evident in the AX50 frame design. Made of heavy gauge steel, the front axle and frame are connected along with a heavier front fender resulting in high strength – even with high lifting heights or a heavy load. It's quality that operators will appreciate – delivering capable performance day after day.

Comfort is critical to operator productivity. And at Komatsu Forklift, we pride ourselves on providing total operator comfort. The result: The Komatsu Komfort Zone, an advanced ergonomic forklift design that isolates the operator from engine vibration, noise and heat.

The Komfort Zone design uses a dual floating structure that protects operators. One set of vibration-dampening mounts separates the forklift's frame from the engine and transmission. A second set of suspension mounts isolates the operator compartment from the frame. In addition, drive-train design reduces vibration transmitted from the differential.

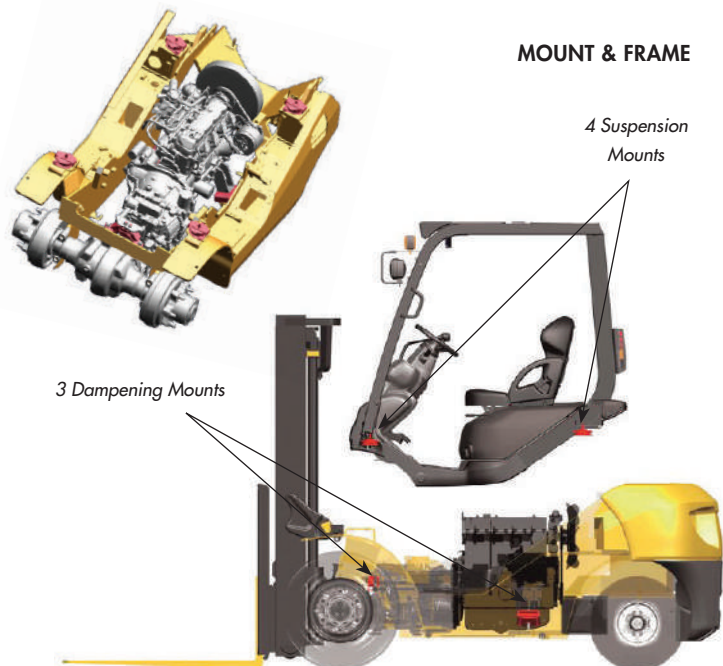

FORWARD/REVERSE LEVER

AX50 controls support easy, intuitive operations to maximize efficiency, reduce fatigue, and shorten learning time. Automotive-style levers for headlights and turn signals work with simple, familiar actions. The forward/reverse lever provides smooth, low-effort shifting — a necessity in environments where the truck constantly changes direction.

FOOT AND HEAD ROOM

Pedals suspended from the dash frame and tilt cylinders located under the floor give the AX50 operator more foot room and floor space. The AX50 overhead guard provides headroom to accommodate operators of all sizes.

ANGLED EXHAUST PORTS

Hot engine air and exhaust gases are tiring to the operator. On the AX50, angled ports aim hot engine air away from the operator while traveling in reverse. Exhaust vents located low on the counterweight keep exhaust gases away from the operator and also away from the floor, to avoid stirring up dust.

STEER AXLE

The AX50 steer axle features an integral double-acting, double-ended cylinder that eliminates drag links and tie rods that wear and require maintenance. High-capacity king-pin needle bearings with heavy-duty seals add durability.

The AX50 dashboard wiring harness, engine wiring harness, and steering control system use the latest generation of waterproof connections for improved reliability — even in wet applications.

EZview®

Operator visibility is a key to productive forklift operations. An EZview mast and console, and a low-profile dash display gives an unrestricted view of the fork tips and surroundings. In the rear of the AX50, the upper corner of the counterweight angles sharply to give optimum visibility when moving in reverse.



« FULLY HYDROSTATIC POWER STEERING

The AX50 Fully Hydrostatic Power Steering (FHPS) system reduces operator fatigue by eliminating kickback and allowing easy steering, even while the forklift is stationary. A small-diameter steering wheel improves operator feel and control, and an optional spinner knob allows easier one-handed steering.

The shape of the dash display was especially designed to give the operator an unrestricted view of the fork tips. The fully instrumented AX50 console keeps the operator informed with displays including:

- » Neutral Indicator
- » Engine Oil Pressure Gauge
- » Low Battery/Alternator
- » Fuel Gauge
- » Hour Meter
- » Komatsu Operator Presence System (KOPS)
Plus Hydraulic Lock Indicator
- » Check Engine Indicator
- » Maintenance Error Code Display
- » Engine Temperature Gauge

90 YEARS OF EXPERIENCE DELIVERS ONE-OF-A-KIND PERFORMANCE

GREATER RELIABILITY. LOWER LIFE-CYCLE COSTS.

With the Komatsu AX50, our expertise and experience is built right in. Improved, high-reliability features that help keep AX50 life-cycle costs low include:

- A two-stage temperature sensing system to protect the AX50 engine from overheating. The engine protection system automatically limits engine speed if coolant temperature rises. If coolant temperatures exceed safe operating limits, the engine protection system will shut the engine down.
- A high-velocity, low-noise ten-blade fan directs air straight through the radiator and across the exhaust system. The contour of the fan shroud increases airflow through the engine compartment. The radiator housing channels air outside to help keep the hood cool, and to prevent recirculation of hot air back into the engine compartment.

HIGH-EFFICIENCY DRIVE TRAIN

A transmission, designed and manufactured by Komatsu Forklift Limited, handles the high torque provided by the powerful K21 engine. A high-capacity oil cooler protects the torque converter, and an aluminum alloy transmission case improves heat dissipation. O-ring face seals designed for high-temperature, high-speed applications reduce the possibility of leaks in the pump, power steering circuit, and torque converter cooler.

The full floating AX50 drive train uses a highly dust-resistant, double-seal universal joint design that has delivered very high reliability in demanding construction machinery applications for many years.

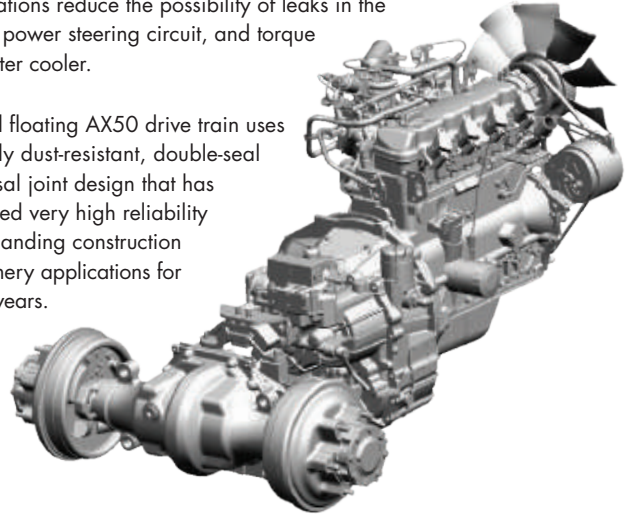

KOPS PLUS

KOPS Plus – standard on the AX50 – locks out lift, lower, tilt and travel functions when the operator leaves the seat for more than three seconds. They do not resume until the operator returns to the seat and resets the controls. A flashing yellow warning light alerts the operator when the KOPS lock is activated. In addition, the AX50 forks cannot be lowered while the key is in the off position.



SIMPLIFIED MAINTENANCE MEANS LOWER COST OF OWNERSHIP



EXTENDED SERVICE INTERVALS

The AX50 offers simplified maintenance and service access that improve your bottom line. Extended service intervals reduce maintenance costs and downtime. An on-board diagnostic system makes troubleshooting with a hand-held diagnostic tool easy.

DAILY CHECKS MADE EASY

There is easy access for daily checks. Brake fluid is checked by simply lifting a cover to the left of the steering wheel. A gas cylinder-assisted engine compartment cover and easy lift-out floorboard give quick access to the engine and other components. The durable one-piece, light-weight, steel engine cover opens with a single latch, allowing for complete access, and a locking device holds the cover open.

SELF-ADJUSTING BRAKES

The self-adjusting, drum-and-shoe brakes are reliable and easy to maintain. Extra thickness in the brake drums improves heat resistance in severe duty applications. Non-asbestos brake linings assure a healthier working environment and an extended lining life.

IMPROVED DURABILITY AND RELIABILITY

A wiring harness leading from a fuse box, conveniently located near the battery, simplifies all inspection and maintenance operations. Waterproof connectors at critical areas are used to assure reliable operation, even in harsh environments.

KOMATSU AX50

In 3,000- or 3,500-pound capacity, the AX50 can minimize operator fatigue, improve the working environment and increase productivity. Indoors, where agility, compact size and operator comfort are essential, and outdoors in challenging conditions that require maximum flexibility and power, the AX50 delivers superior performance and reduced operating costs. Put the AX50 on your job site now.

Building on our 90 year history of superior engineering, the AX50 delivers improved performance, unbeatable strength, greater reliability, and lower life-cycle costs while handling your most demanding applications.

AX50

PNEUMATIC TIRE FORKLIFTS

STRONG CUSTOMER SATISFACTION

Komatsu Forklift has a strong corporate commitment to produce, deliver and support quality products, and we have always made customer satisfaction our top priority. We will work to the best of our ability to help you maximize your operation's productivity while minimizing costs.

QUALITY PRODUCTS & SERVICES

Komatsu Forklift offers an expanding product line of electric and internal combustion engine forklift models with capacities from 2,000 to 35,000 pounds. We back them with a complete warranty program, superior service, and genuine OEM parts.

CONTACT YOUR DEALER TODAY

Your nearby Komatsu Forklift dealer is ready to assist you. Ask about financing and leasing programs that can be tailored to your business plan. Forklifts for your specific applications and workplace are waiting for you now.

KOMATSU DEALER NETWORK

Komatsu Forklift has dealer locations throughout the United States, Canada, Mexico, the Caribbean, and Central and South America. Komatsu dealers are staffed with dedicated teams of professionals who are trained to meet your forklift needs.

THE KOMATSU HERITAGE

As part of the Komatsu family, we have a proud heritage of excellence in equipment design and manufacturing. Since 1921 Komatsu has been a global leader in the construction and mining equipment industry. And since 1945, we have built upon that heritage by producing innovative, high-quality, durable forklifts to meet and exceed the needs of our customers.



KOM84-02

©2013 Komatsu America Corp.

Printed in USA

D02(2M)KM

09/20 (EV-2)

KOMATSU®

www.KomatsuAmerica.com

www.KomatsuForkliftUSA.com

Komatsu America Corp. is an authorized licensee of Komatsu Ltd. Materials and specifications are subject to change without notice.

Photos may include optional equipment.
KOMATSU is a registered trademark of Komatsu Ltd., Japan